

## Extend Your Lift Truck's Reach With Telescopic Forks

*Load and unload  
trucks and  
trains from  
one side.*

### APPLICATION

Increase the efficiency of your forklift truck by using Cascade Telescopic Forks. Trucks and trains can be loaded and unloaded from one side - No need to move back and forth to either side of the vehicle. Telescopic forks consist of a stationary basic fork and a movable, telescopic, outer fork which is connected to a piston rod. Telescopic forks come in two different models, the standard model; and a slim model made with smaller fork sections which are especially useful for providing easy maneuverability with smaller pallets.

### FEATURES

- A flow divider, supplied with each set of Telescopic Forks and Fork Extensions, assures equal fork movement.
- High grade steel and a solid cast nose improves wear ability.
- A reinforced heel design improves deflection.
- Hydraulic connections are protected behind a guard.

### OPTIONS

- Special mountings available.
- Pallet Stops to prevent fork from protruding too far outside pallet.
- Can be integrated onto a Fork Positioner.
- Load Backrest to support load when moving forward.
- Wearstrips under forks to improve fork life.
- Available in a variety of fork lengths and strokes.



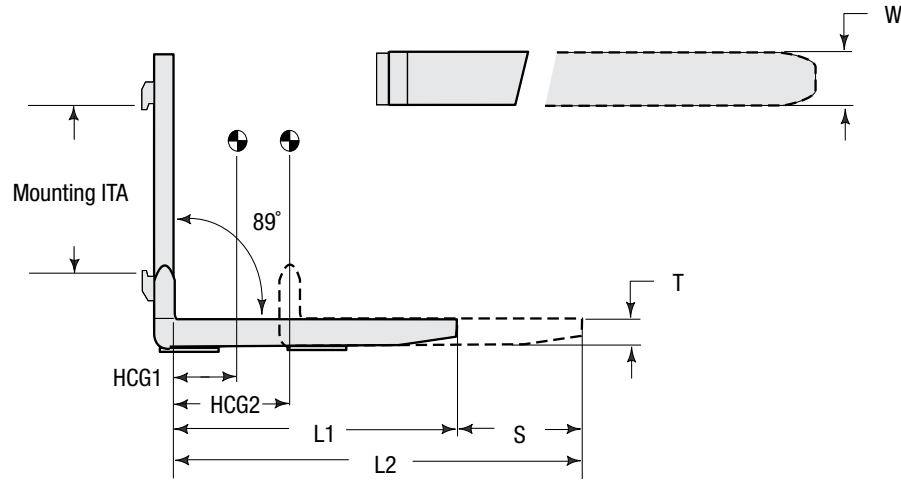

## Hook-on

Catalog Order No.	Capacity @ 24" (600 mm) Load Center		Capacity @ 68" (1725 mm) Load Center		Mtg. Class	Fork Thickness T	Fork Width W	Fork Length (Retracted) L1	Fork Length (Extended) L2	Stroke S	Horizontal Ctr. of Gravity HCG 1	Horizontal Ctr. of Gravity HCG 2	Weight (Per Pair)	
	Lbs.	kg	Lbs.	kg									lb.	kg
55B-TFQ-A041	5,500	2500	1,870	850	II	2.2"	6.7"	43.3"	72.8"	29.5"	15.4"	19.7"	450	204
55B-TFQ-A042	5,500	2500	1,870	850	II	2.2"	6.7"	47.3"	80.7"	33.4"	17.3"	22.0"	485	220
55B-TFQ-A043	5,500	2500	1,870	850	II	2.2"	6.7"	53.1"	92.5"	39.4"	19.7"	25.6"	530	240
77B-TFQ-B041	7,700	3500	2,640	1200	III	2.2"	6.7"	43.3"	72.8"	29.5"	15.7"	19.3"	530	240
77B-TFQ-B042	7,700	3500	2,640	1200	III	2.2"	6.7"	47.3"	80.7"	33.4"	17.3"	21.7"	560	254
77B-TFQ-B043	7,700	3500	2,640	1200	III	2.2"	6.7"	53.1"	92.5"	39.4"	19.7"	25.2"	605	274
100B-TFQ-B041	10,000	4500	3,390	1540	III	2.2"	6.7"	43.3"	72.8"	29.5"	15.0"	18.9"	460	208
100B-TFQ-B042	10,000	4500	3,390	1540	III	2.2"	6.7"	47.3"	80.7"	33.4"	16.9"	21.7"	495	225
100B-TFQ-B043	10,000	4500	3,390	1540	III	2.2"	6.7"	53.1"	92.5"	39.4"	19.7"	25.2"	540	245
130B-TFQ-C041	13,000	5800	4,370	1985	IV	2.5"	6.7"	43.3"	72.8"	29.5"	15.7"	15.4"	550	249
130B-TFQ-C042	13,000	5800	4,370	1985	IV	2.5"	6.7"	47.3"	80.7"	33.4"	17.3"	22.4"	595	270
130B-TFQ-C043	13,000	5800	4,370	1985	IV	2.5"	6.7"	53.1"	92.5"	39.4"	19.7"	26.0"	650	294
175B-TFQ-C041	17,500	7700	5,810	2640	IV	2.5"	8.9"	43.3"	72.8"	29.5"	14.2"	18.5"	815	370
175B-TFQ-C042	17,500	7700	5,810	2640	IV	2.5"	8.9"	47.3"	80.7"	33.4"	15.7"	20.9"	870	395
175B-TFQ-C043	17,500	7700	5,810	2640	IV	2.5"	8.9"	53.1"	92.5"	39.4"	18.1"	24.4"	935	424
230B-TFQ-C041	23,000	10500	7,920	3600	IV	3.0"	8.9"	43.3"	72.8"	29.5"	14.2"	18.1"	960	435
230B-TFQ-C042	23,000	10500	7,920	3600	IV	3.0"	8.9"	47.3"	80.7"	33.4"	15.7"	20.5"	1,015	460
230B-TFQ-C043	23,000	10500	7,920	3600	IV	3.0"	8.9"	53.1"	92.5"	39.4"	18.5"	23.6"	1,100	499

► Supplied with flow divider valve to be mounted on truck carriage.