



Technical Bulletin

Leakage Service Procedure for 55K Installation Kits

This bulletin covers applying Loctite 5452 Thread Sealant (purple) to units observed to have leakage at the sideshift cylinder's manifold fitting equipped on 55K Fork Positioners. Perform the following procedure on units in the field with installation Kits 6886080, 6958174, 6940589 or 6953757.

Service Procedure

The following procedure can be performed with the attachment installed on the truck.

- 1 Position the forks to gain access to the manifold side of sideshift cylinder port.



WARNING: Before removing any hoses, relieve pressure in the hydraulic system. With the truck off, open the truck auxiliary control valve (or valves) several times in both directions.

- 2 Disconnect and plug the hoses from the manifold on the sideshifter cylinder. Tag for reassembly.
- 3 Disconnect and remove the manifold from the sideshift cylinder.
- 4 Remove the fitting (No. 6 O-ring male) from the manifold. Clean and dry fitting.
- 5 Apply a small bead of Loctite 5452 Thread Sealant (purple) around the fittings leading threads on each end. Back the locknut off as far as possible. Apply a small bead the locknut threads.
IMPORTANT: Make sure the sealant does not get on fitting front face, inside the fitting or on the O-ring.
- 6 Install fitting to sideshift cylinder and manifold. The side with the adjustable nut installs into the sideshift cylinder. Allow one hour for cure time.
- 7 Install hoses.

Procedure continued on next page

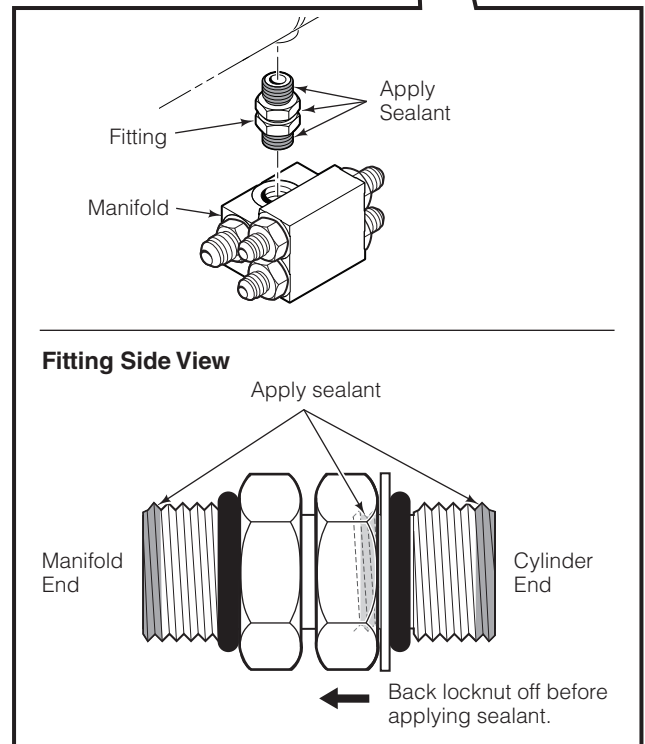
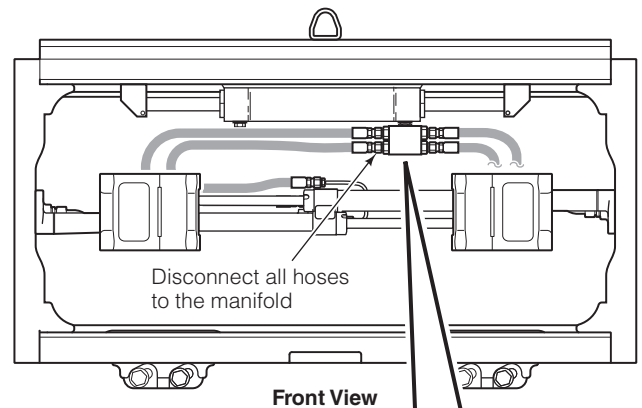

FP4017.ai

NOTE: This information should not be interpreted as the basis for warranty claims unless so designated.

cascade[®]
corporation

Part No. 9020294-R2

For Technical & Warranty Support . . .

Call: 1-800-227-2233
Email: Tech-Support-Team@cascorp.com
Internet: www.cascorp.com

To Order Parts . . .

Call: 1-888-227-2233
Email: parts@cascorp.com
Internet: www.cascorp.com

Service Procedure (continued)

- 8 If present, remove all cable ties from the rolling hoses shown.

CAUTION: Do not secure additional hoses to rolling hoses. If unavoidable, cable ties securing additional hoses to rolling hoses must be installed only to the right of the frame centerline (front view).

- 9 Cycle the attachment through several cycles to confirm leakage has stopped.

