

# ***INSTALLATION INSTRUCTIONS***

---

***and PERIODIC MAINTENANCE***

## ***H-Series***

***Fixed Frame***

***Pivot Arm***

***Paper Roll Clamps***

***Original Instructions***

***Number 6077316-R11 EN***



**cascade<sup>®</sup>  
corporation**

Cascade is a Registered Trademark of Cascade Corporation

# CONTENTS

---

<u>Warnings and Safety Information</u>	<u>1</u>
<u>Recommended Hydraulic Supply</u>	<u>2</u>
<u>Truck Requirements</u>	<u>3</u>
<u>Installation</u>	<u>5</u>
<u>Periodic Maintenance</u>	<u>14</u>
<u>Nameplate Icons</u>	<u>19</u>

This manual provides installation instructions and periodic maintenance for Cascade H-Series Fixed Frame Paper Roll Clamps.

Follow the suggested installation procedures for best results. If you have any questions or need more information, contact your nearest Cascade Service Department for assistance. Refer to back cover.

Read the **WARNING** Statements placed throughout this manual to emphasize safety during attachment installation.

**IMPORTANT:** Field alterations may impair performance or capability and could result in loss of warranty. Consult Cascade for any required modifications.

**IMPORTANT:** Supply input fittings are JIC.

**NOTE:** All specifications are shown in metric units where applicable. All fasteners have a torque value range of  $\pm 10\%$  of stated value.

**Weighted Emission Sound Pressure Level** - Weighted emission sound pressure level (LpA) does not exceed 70 dB(A).

**Measured Value of Whole Body Vibration** - Measured value of whole body vibration ( $m/s^2$ ) does not exceed 0,5  $m/s^2$ .

**Measured Value of Hand-Arm Vibration** - Measured value of hand-arm vibration ( $m/s^2$ ) does not exceed 2,5  $m/s^2$ .

## Disposal

At the end of life of the equipment, all the parts must be disassembled and cleaned of grease and hydraulic oils. Prepare containers for the collection of hydraulic fluids and greases. Dispose of the device according to the applicable regulations in your country.

**IMPORTANT:** Do not dispose equipment along with household waste.

# WARNINGS AND SAFETY INFORMATION

**IMPORTANT:** All safety regulations that apply to the truck remain valid and unchanged. Always follow the operating, maintenance and repair instructions for the truck.



**WARNING:** Before starting any work on the unit, the operator must wear the appropriate personal protective equipment (PPE) such as gloves, eye protection and safety shoes. Refer below for more information.

**WARNING:** Residual risk exists to pedestrians, bystanders and service technicians in the work area. Operate lift trucks and accessory equipment in a safe working area and in compliance with facility, local and national standards and rules.

**WARNING:** Equipment can be HOT and cause personal injury. Do not touch or service the components, hose and fittings if the temperature is over 48° C. Do not allow skin contact with oil. If any contact occurs, refer to the vendor's fluid safety data sheet.

**WARNING:** To avoid damage, do not use aggressive cleaners or solvent-based substances to clean labels or adhesives.

## Residual Hazards

The equipment in your possession has been designed in order to prevent the risk during moving, installation and use operations. There are, however, some residual hazards:

- Hazard of crushing between the truck's front structure and the lifting set when completely tilted backwards.
- Hazard of shearing between the truck's front structure and the parts that move vertically with the lifting set completely tilted backwards.
- Hazard of crushing if arms are left open and in horizontal position in resting position.
- Hazard of shearing between the fixed frame and arms while moving.
- Hazard of crushing/shearing between the chains and the relative pulleys and the transversal connections of the mast.
- Hazard of crushing during arm removal and replacement phases.
- Hazard of crushing during cylinder disassembly and replacement phases.
- Hazard of crushing during installation and maintenance operations.
- Hazard of electric shock in case of presence of electrical components on the equipment during the installation, use and maintenance phases.

## Personal Protective Equipment (PPE)

It is mandatory to use personal protective equipment (PPE) during handling, installation, operation and maintenance of the attachment. Specifically:

- Using gloves to prevent contact with oils and greases used for lubricating the attachment and unscrewing adhesive products;
- Use suitable footwear, goggles and gloves for handling the attachment. Be aware of sharp edges on the attachment;
- Use hearing protection in excessively noisy environments, with the exception of driving. Follow the safety requirements for driving and operating the truck.
- Additionally, use of other PPE that is site-specific or required by local safety authorities.

# RECOMMENDED HYDRAULIC SUPPLY

The Cascade H-Series Fixed Frame Paper Roll Clamps can be operated with any of the hydraulic supply arrangements shown below. Refer to *Cascade Hose & Cable Reel Selection Guide*, Part No. 212199, to select the correct hose reel for the mast and truck. Hose and fitting requirements are as follows:

- **10H** – All hoses and fittings for both CLAMP and ROTATE functions require No. 4 hose with 6 mm minimum ID.
- **13H,18H** – All hoses and fittings for both CLAMP and ROTATE functions require No. 6 hose with 7 mm minimum ID.
- **20H-75H** – All hoses and fittings for both CLAMP and ROTATE functions require No. 8 hose with 10 mm minimum ID.

**CAUTION:** Rotate function supply circuit back pressure exceeding 35 bar can result in excessive oil heating, reduced attachment performance and shortened hydraulic system life. Check for restrictions such as numerous fittings and fitting/hose sizes less than No. 4 (10H), No. 6 (13H,18H) or No. 8. (20H-75H).

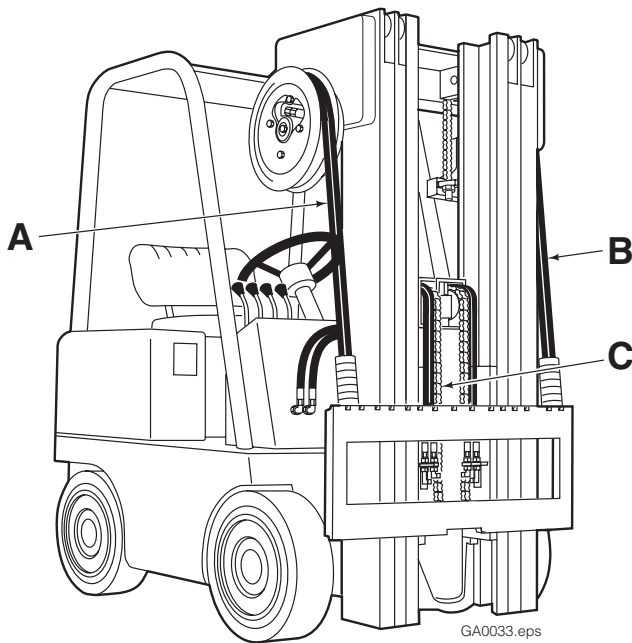

## Standard

### A and B

RH and LH THINLINE™ 2-Port Hose Reel Groups

### OR

### A and C

RH THINLINE™ 2-Port Hose Reel Group and Mast Single Internal Hose Reeving Group

### OR

C Mast Double Internal Hose Reeving Group

## Solenoid Equipped

B LH 6-N-1 Cable Hose Reel

# TRUCK REQUIREMENTS

## Truck Relief Setting

160 bar (16,0 MPa) Maximum

## Truck Flow Volume <sup>①</sup>

	Min. <sup>②</sup>	Recommended	Max. <sup>③</sup>
<b>ROTATE Circuit</b>			
<b>10H, Low Flow</b>	4 l/min	11 l/min	19 l/min
<b>10H</b>	11 l/min	19 l/min	30 l/min
<b>13H, 18H</b>	19 l/min	38 l/min	45 l/min
<b>20H, 22H, 24H, 25H, 30H</b>	19 l/min	138 l/min	57 l/min
<b>33H, 34H, 38H, 42H, 46H, 55H, 68H, 75H</b>	38 l/min	57 l/min	76 l/min
<b>CLAMP Circuit</b>			
<b>10H, Low Flow</b>	4 l/min	11 l/min	30 l/min
<b>10H</b>	11 l/min	19 l/min	30 l/min
<b>13H, 18H</b>	19 l/min	38 l/min	57 l/min
<b>20H 22H, 24H, 25H, 30H</b>	19 l/min	32 l/min	57 l/min
<b>33H, 34H, 38H, 42H, 46H, 55H</b>	38 l/min	57 l/min	76 l/min
<b>68H, 75H</b>	57 l/min	75 l/min	95 l/min

- ① Cascade Paper Roll Clamps are compatible with SAE 10W petroleum base hydraulic fluid meeting Mil. Spec. MIL-0-5606 or MIL-0-2104B. Use of synthetic or aqueous base hydraulic fluid is not recommended. If fire resistant hydraulic fluid is required, special seals must be used. Contact Cascade.
- ② Flow less than recommended will result in a rotate speed less than 2 RPM.
- ③ Flow greater than maximum can result in excessive heating, reduced system performance and short hydraulic system life.



**WARNING:** Rated capacity of the truck/attachment combination is a responsibility of the original truck manufacturer and may be less than that shown on the attachment nameplate. Consult the truck nameplate.

## Carriage

Clean carriage bars and inspect carriage bars. Make sure the bars are parallel and that ends are flush. Repair any protruding welds or damaged notches.

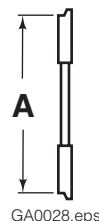
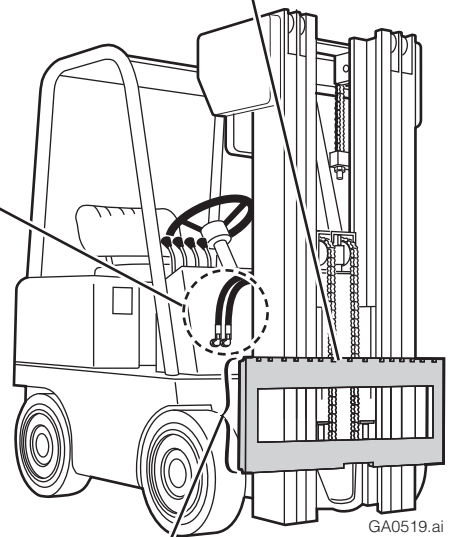

GA0028.eps

## Carriage Mount Dimension (A) ISO

	Minimum	Maximum
<b>Class II</b>	380.0 mm	381.0 mm
<b>Class III</b>	474.5 mm	476.0 mm
<b>Class IV</b>	595.5 mm	597.0 mm

# TRUCK REQUIREMENTS

## Auxiliary Valve Functions

Check for compliance with ISO standards:

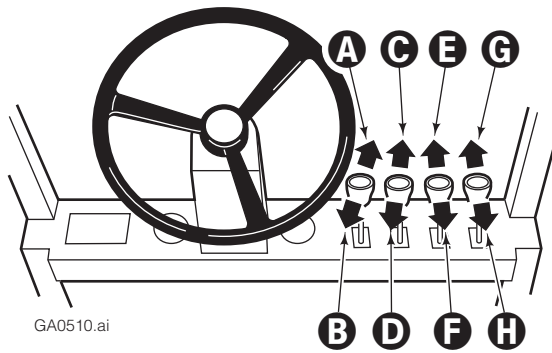

### Main Functions

**A** Hoist Down

**B** Hoist Up

**C** Tilt Forward

**D** Tilt Back

### Auxiliary Functions

#### Standard

**E** Rotate CCW

**F** Rotate CW

**G** Release

**H** Clamp

#### Solenoid Equipped

**E** Rotate CCW **OR** Release (Push Button)

**F** Rotate CW **OR** Clamp (Push Button)



**WARNING:** Truck control handle and attachment function activation shown here conforms to ISO 3691 recommended practices. Failure to follow these practices may lead to serious bodily injury or property damage. End user, dealer and OEMs should review any deviation from the practices for safe operation.

# INSTALLATION

Follow the steps shown to install the attachment on the truck. Read and understand all **WARNING** statements. If a procedure is not understood, ask a supervisor, or call the nearest Cascade Service Department for assistance.

**IMPORTANT:** The installer is responsible for attachment installation and maintenance of the truck/attachment combination.

## 1 Attach overhead hoist

- A** Remove banding, set attachment upright on pallet.
- B** Remove bolt-on lower mounting hooks, if equipped.

**WARNING:** Verify that the overhead hoist and chains or straps are rated for the weight of the attachment. Refer to nameplate for attachment weight.

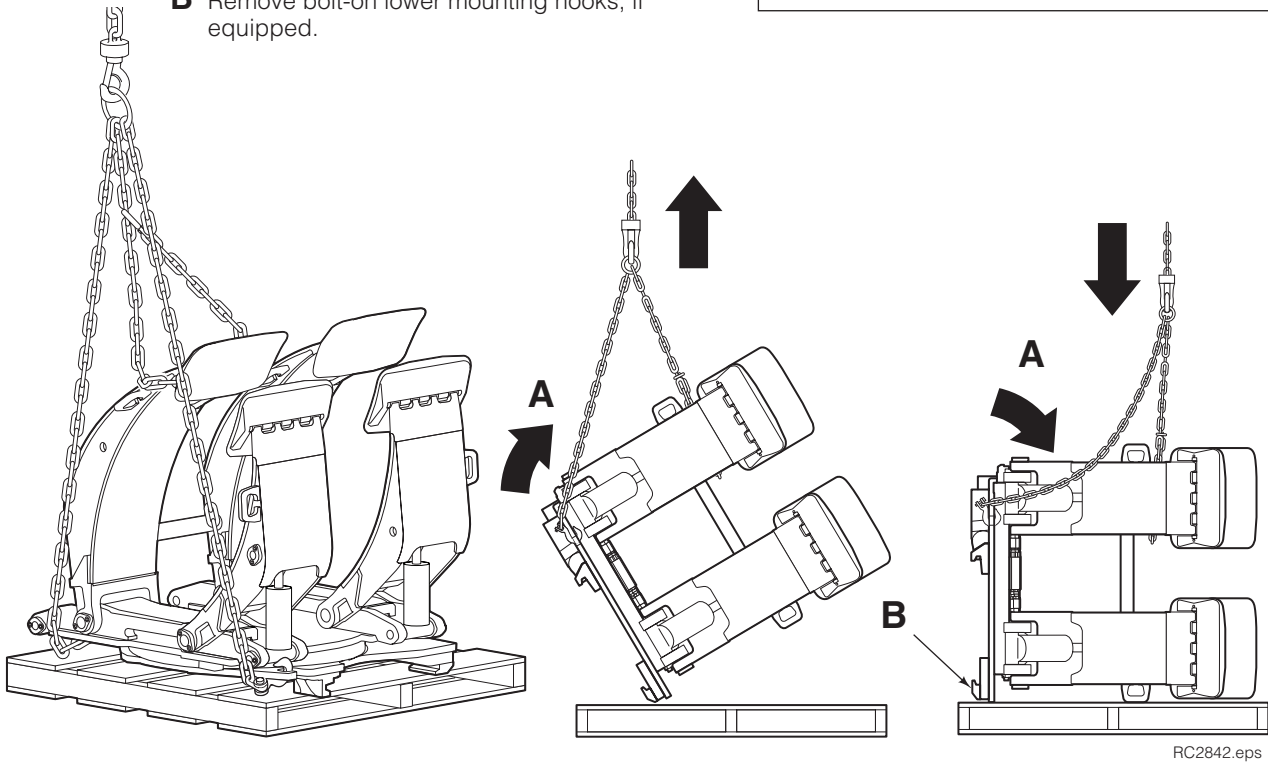

## 2 Unlock quick-change lower mounting hooks, if equipped

- A** Pull Pin.
- B** Move hooks into unlocked position.

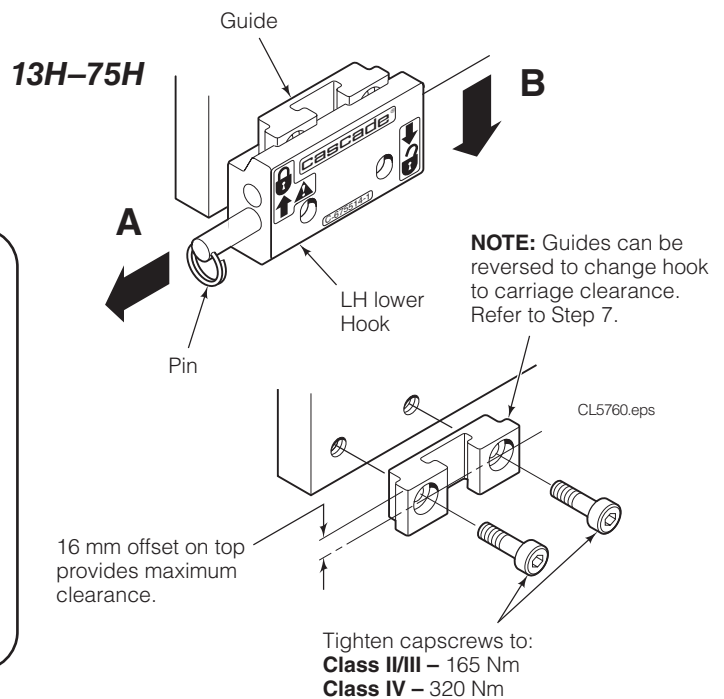
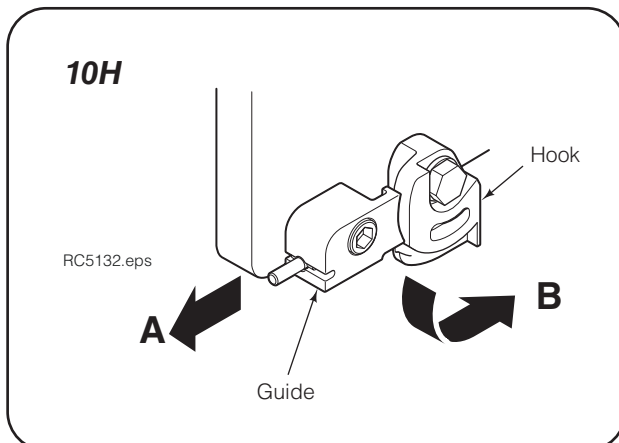

# INSTALLATION

## 3

### Prepare Hoses

- A** Determine hose lengths required for hydraulic supply.
- B** Cut hoses to length, install end fittings or quick disconnect kits.

**CAUTION:** Rotate function supply circuit back pressure exceeding 35 bar can result in excessive oil heating, reduced attachment performance and shortened hydraulic system life. Check for restrictions such as numerous fittings and fitting/hose sizes less than No. 4 (10H), No. 6 (13H, 18H) or No. 8. (20H-75H).

**CAUTION:** Use No. 4 Hoses (10H), No. 6 Hoses (13H, 18H) and No. 8 Hoses (20H-75H), 160 bar working pressure rated for all functions.

10H

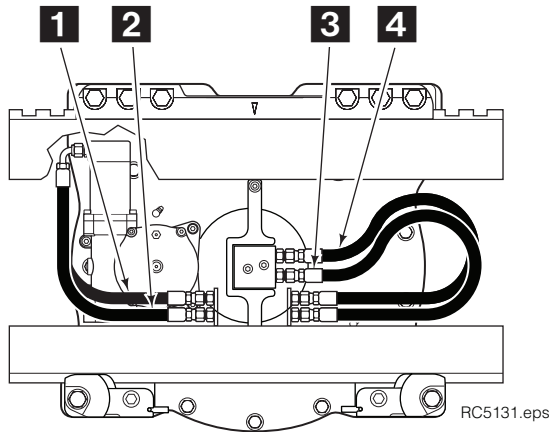

- 1** Rotate Counterclockwise
- 2** Rotate Clockwise
- 3** Release
- 4** Clamp

**DOUBLE INTERNAL HOSE REEVING**

13H, 18H

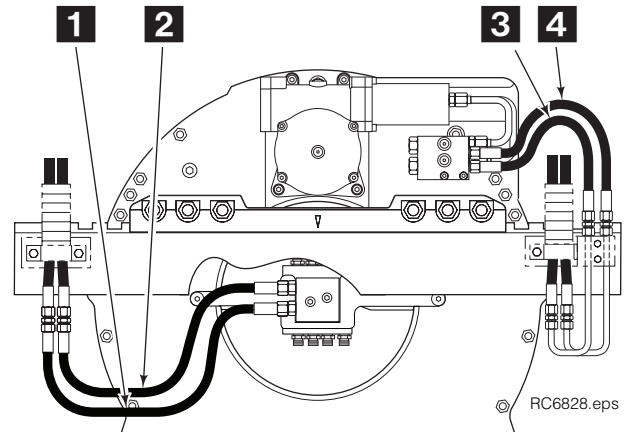

- 1** Clamp
- 2** Release
- 3** Rotate Clockwise
- 4** Rotate Counterclockwise

**RH & LH 2-PORT THINLINE™ HOSE REELS**

20H-46H

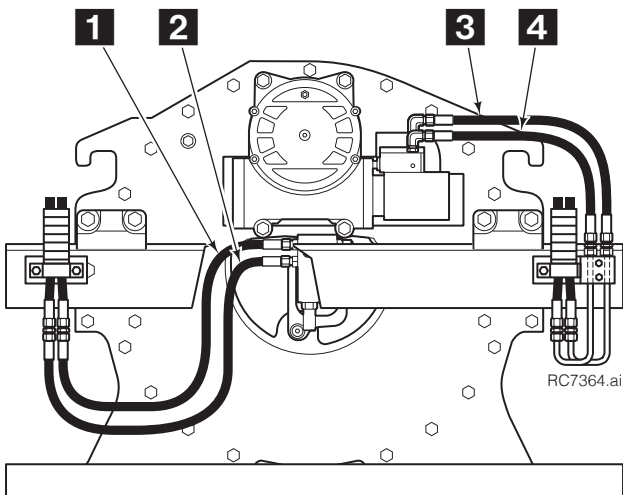

- 1** Release
- 2** Clamp
- 3** Rotate Counterclockwise
- 4** Rotate Clockwise

**RH & LH 2-PORT THINLINE™ HOSE REELS**

20H-46H, Solenoid Equipped

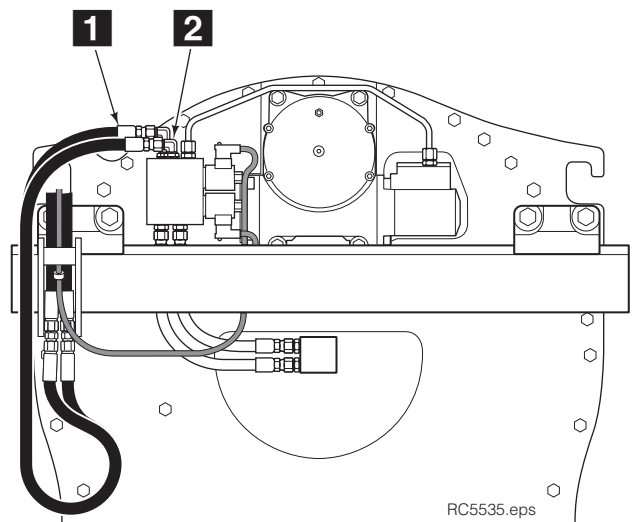

- 1** Rotate Clockwise / Release
- 2** Rotate Counterclockwise / Clamp

**LH 6-N-1 CABLE HOSE REEL**

Back (Driver's) Views

## 3 Prepare Hoses (continued)

55H

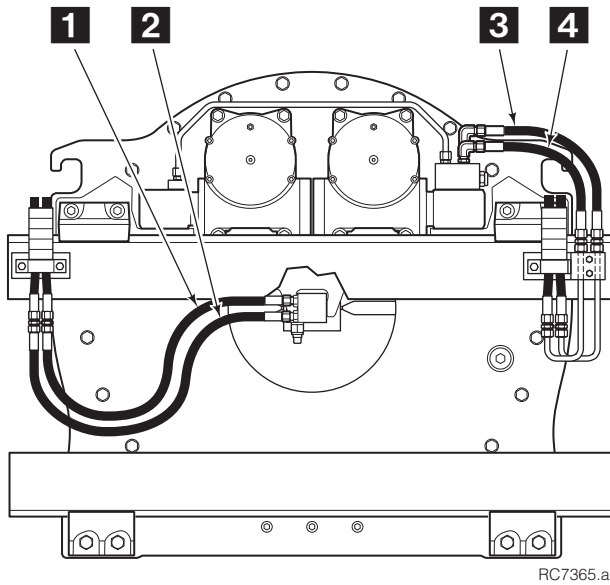

RC7365.ai

68H, 75H

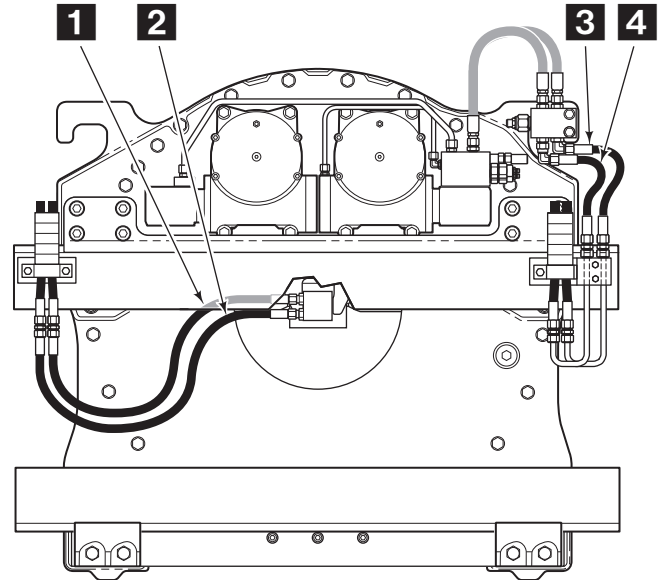

RC7368.ai

- |                  |                                  |
|------------------|----------------------------------|
| <b>1</b> Release | <b>3</b> Rotate Counterclockwise |
| <b>2</b> Clamp   | <b>4</b> Rotate Clockwise        |

### RH & LH 2-PORT THINLINE™ HOSE REELS

## 4 Flush hydraulic supply hoses

- A** Install hoses using union fittings.
- B** Operate auxiliary valves for 30 seconds.
- C** Remove union fittings.

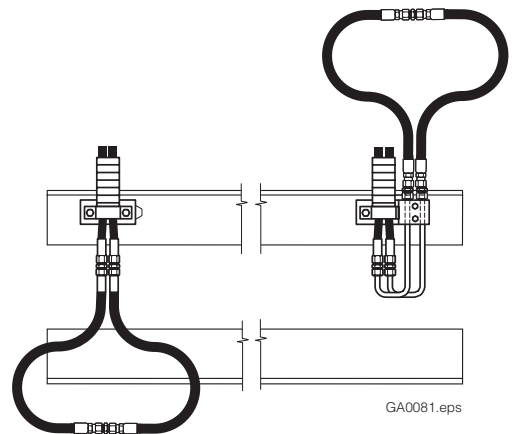

GA0081.eps

## 5 Mount attachment on truck carriage

- A** Center truck behind the attachment.
- B** Tilt mast forward and raise carriage into position.
- C** Engage top mounting hooks with carriage.

**Single Upper Hook equipped** – Make sure the centering tab engages the center notch on top carriage bar.

**Two Upper Hooks equipped** – Make sure left hook locator tab engages the closest notch on top carriage bar.

- D** Lift attachment 5 cm off pallet. Make sure lower index block (if equipped) engages fork slot on lower carriage bar.

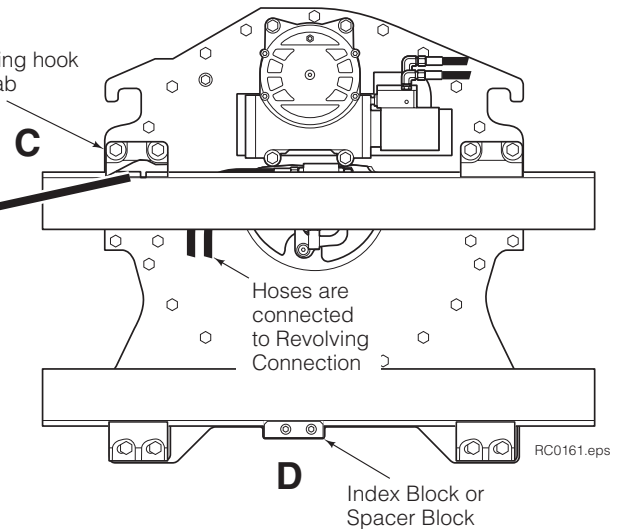
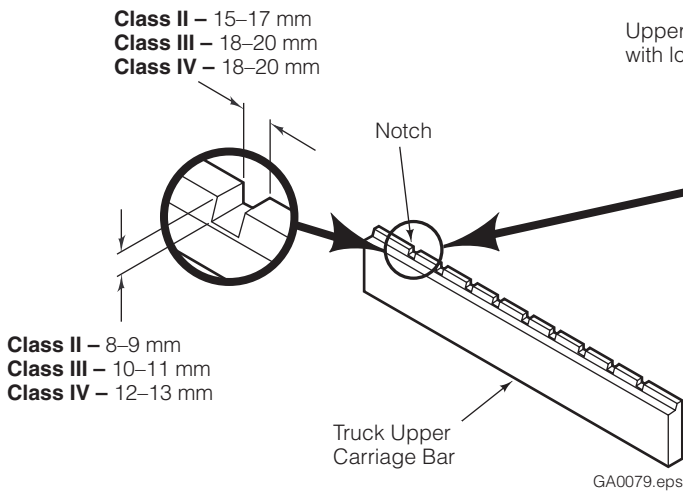
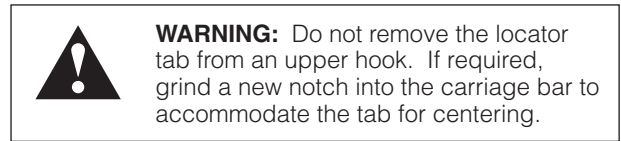
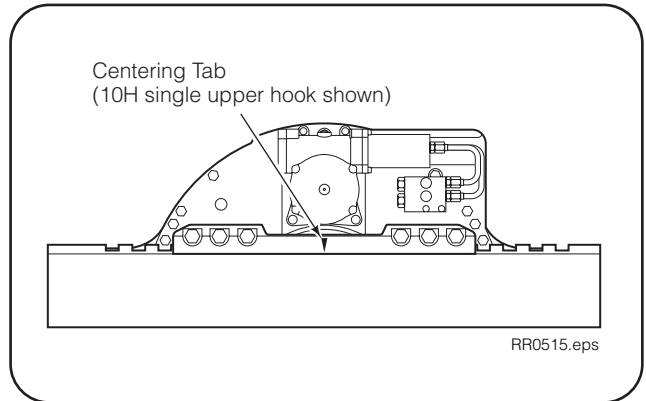

# INSTALLATION

## 6 Remove gearbox oil level fitting, check lubricant level. Remove vent cap.

If necessary, fill gearbox with Cascade Gear Lube 656300 or equivalent SAE 90 wt. gear lube (AGMA 'mild' 6EP Gear Oil).

**NOTE:** Use funnel or squeeze bottle to assist with adding lubricant. If access to the fill hole location is limited, fill using the vent hole. Prior to filling, remove fill hole fitting to watch lubricant level.

**13H, 18H**

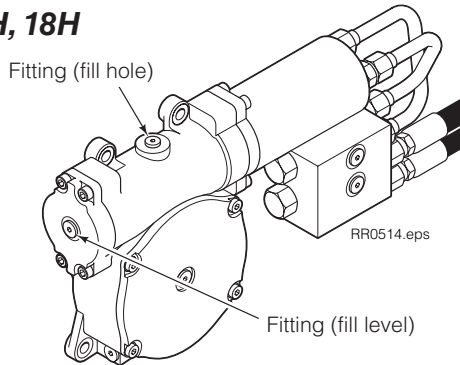

**10H**

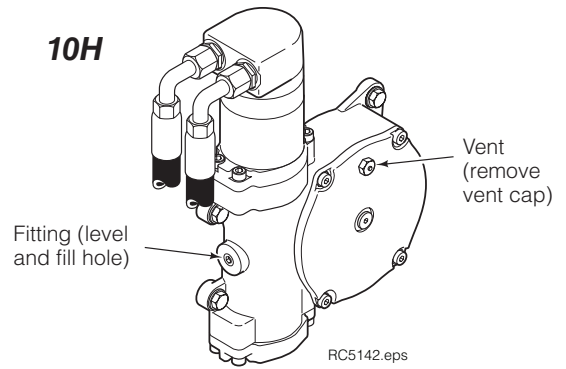

**20H-75H**

(Single Drive shown)

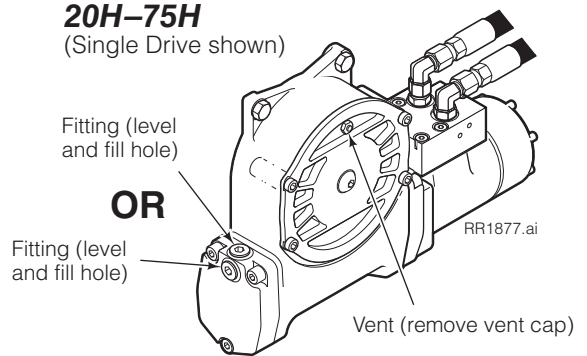

## 7 Install and engage lower hooks

**10H-75H**

**BOLT-ON TYPE**

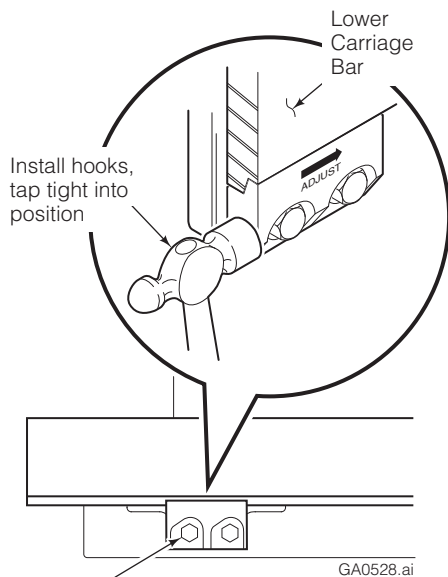

Tighten capscrews to:  
**Class II/III** – 165 Nm  
**Class IV** – 320 Nm

**QUICK-CHANGE TYPE (OPTIONAL)**

**10H**

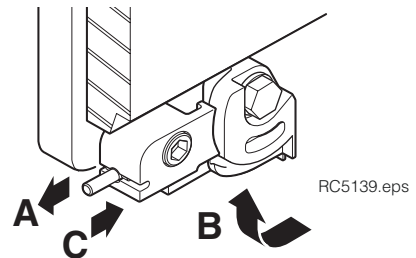

**13H-75H**

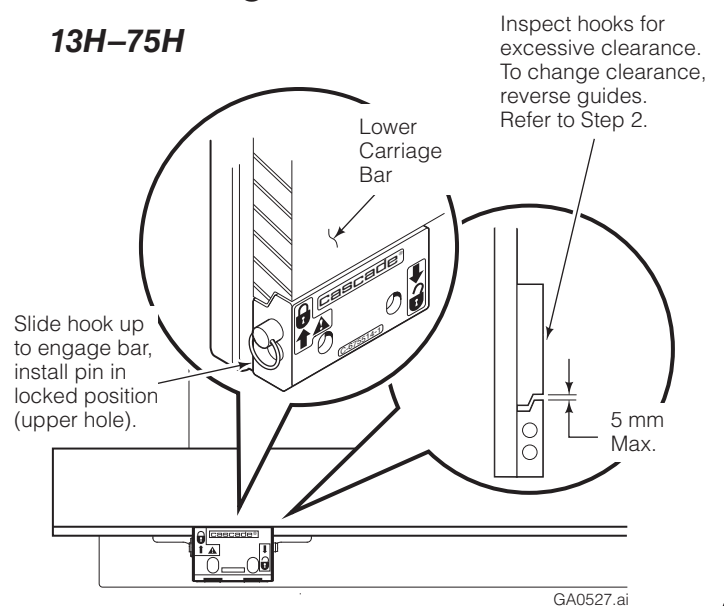

## 8

Connect hoses to carriage hose terminal fittings

10H

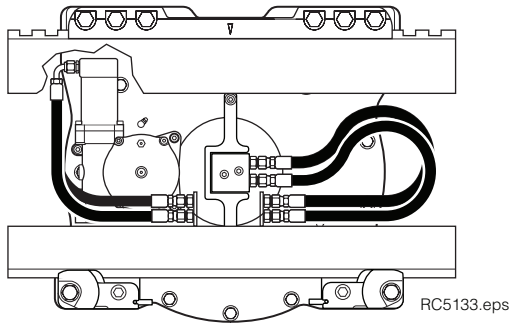

DOUBLE INTERNAL HOSE REEVING

13H, 18H

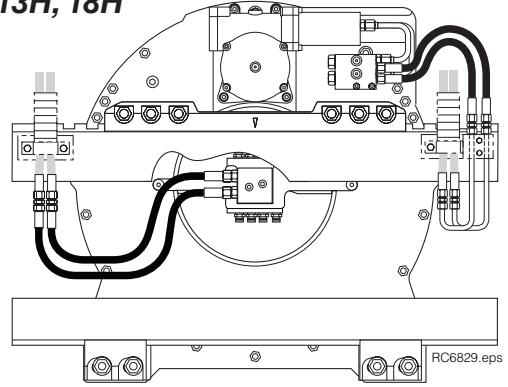

RH & LH 2-PORT THINLINE™ HOSE REELS

20H-46H

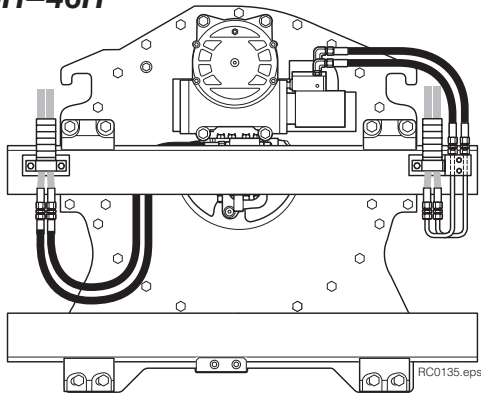

RH & LH 2-PORT THINLINE™ HOSE REELS

55H

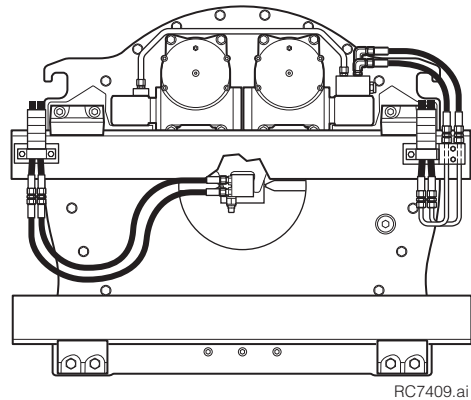

68H, 75H

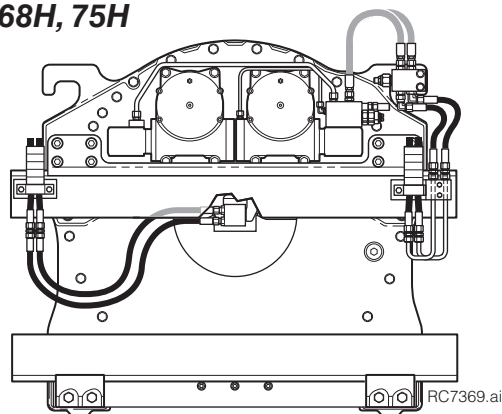

RH & LH 2-PORT THINLINE™ HOSE REELS

Back (Driver's) Views

## 9 Install stop block kit

- Locate a stop block on the outward side of each upper hook. Preheat each stop block and carriage bar weld area to 180 °C.
- Use AWS E7018 low hydrogen rod and weld a 6 mm fillet full length on three sides of each stop block.

**NOTE:** Stop blocks can be welded on the inward side of the upper hooks if carriage width is too narrow for outward placement.

### TWO UPPER HOOKS EQUIPPED

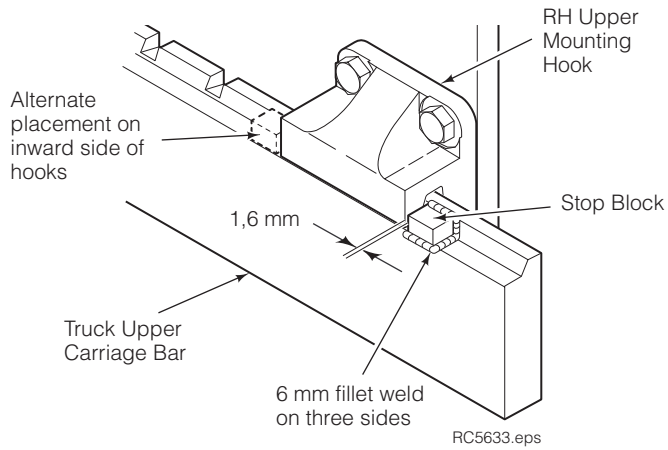

### SINGLE UPPER HOOK EQUIPPED

(10H single upper hook shown)

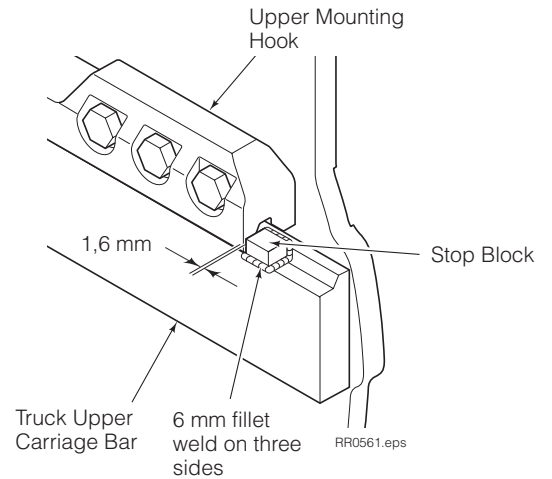

## 10

### Adjust 180° stop valve (if equipped/required)



**WARNING:** Make sure all personnel are clear of attachment during adjustment.

#### A Valves with One Adjustment Screw –

Loosen the jam nut on the stop valve adjustment screw and turn the screw IN (clockwise) until it stops. Back out one turn.

#### Valves with Two Adjustment Screws –

Loosen the jam nut on the stop valve adjustment screws and turn the screws OUT (counterclockwise) until a groove marking the maximum-out position is visible. Adjustment screws should be adjusted equally.

**IMPORTANT:** Backing the adjustment screws out past the groove will cause hydraulic leakage.

**B** Using a load that: A) is the heaviest to be lifted, or B) requires maximum motor torque, rotate the attachment back and forth to the stops at full speed for 1–2 minutes before making adjustments. Observe whether the attachment fully completes its rotation slowly into the hard stop.

**C** If rotation does not continue into the hard stop, rotate the stop valve off the ramp and turn the adjustment screw IN (clockwise) one-eighth turn. Test for complete rotation slowly into the hard stop.

**D** Repeat Step C until the attachment fully completes its rotation slowly into the hard stop. Tighten the jam nut on the adjustment screw.

**E** Check the torque on the stop block capscrews and tighten to 110 Nm, if necessary.

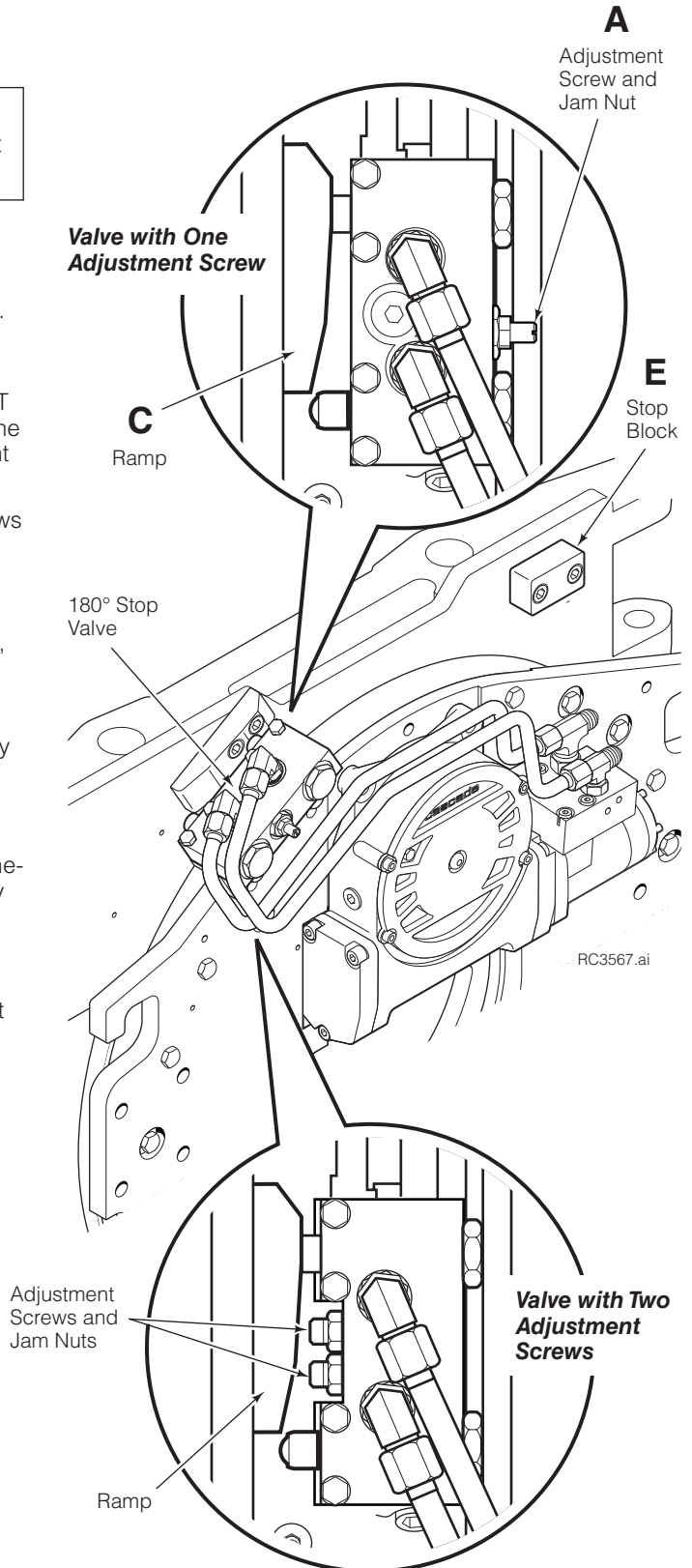

## 11 Cycle attachment functions

- With no load, cycle all functions several times.
- Check functions for operation in accordance with ISO standards.
- Clamp and rotate a maximum load, check for smoothness and normal rotation.
- Check for leaks at fittings and cylinder rod ends.

 **WARNING:** Make sure all personnel are clear of attachment during testing.

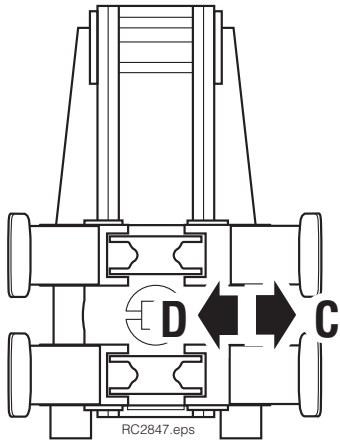
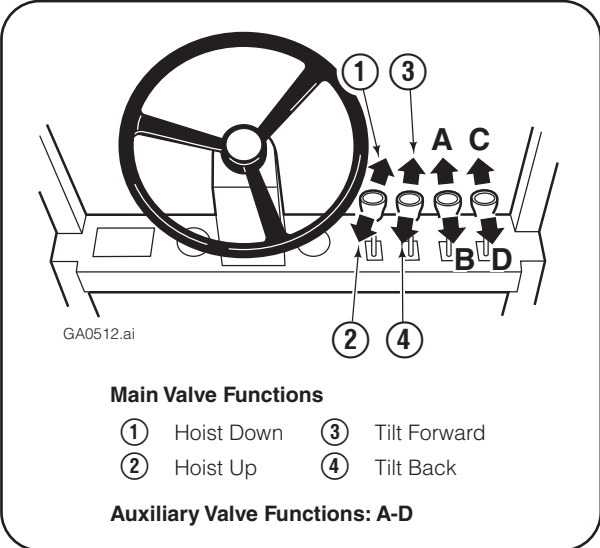

Vertical Position

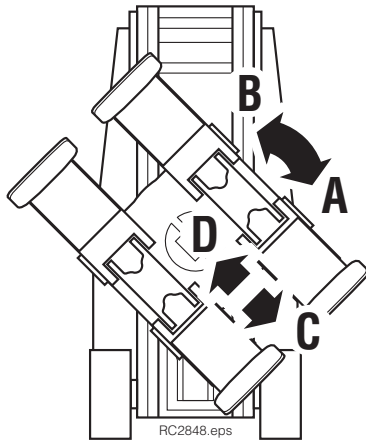

Rotated 45-degrees

### Rotate

(Driver's view)

**A** Counterclockwise (CCW)

**B** Clockwise (CW)

### Clamp – Long Arm

(vertical & horizontal positions only)

**C** Release

**D** Clamp

### Clamp – Short Arm

(45 degree position only)

**C** Open

**D** Close

 **WARNING:** Truck control handle and attachment function activation shown here conforms to ISO 3691 recommended practices. Failure to follow these practices may lead to serious bodily injury or property damage. End user, dealer and OEMs should review any deviation from the practices for safe operation.

The following identification decal (located on the baseplate), shows how the split-arm roll clamp functions:

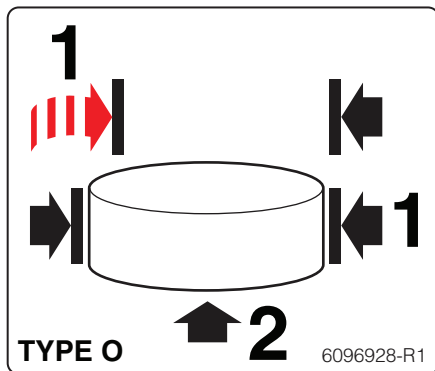

Clamp force is developed without the need for the top arm to fully close.

OR

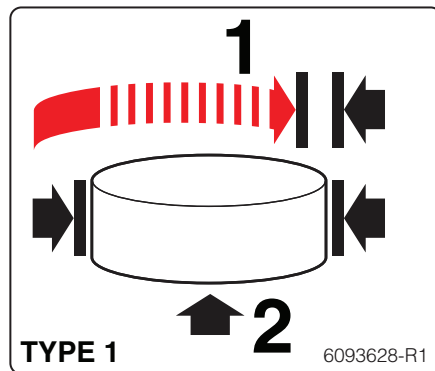

RC4075.eps

The top arm must fully close before clamp pressure is developed.

## 10H-18H

### Prior to Maintenance

Before performing any maintenance procedure, verify the following:

- Relieve hydraulic system pressure,
- Make sure the oil is cool,
- If necessary, operate with the set truck/equipment in a stable position defined by the truck manufacturer.

### Daily Inspection

Check items shown each day. Report problems to a supervisor. Refer to service manual for troubleshooting, maintenance and repair procedures.

- Check for the following:
  - Loose or missing hardware,
  - Worn or damaged hoses,
  - Hydraulic leaks
- Check edges of contact pads for wear or sharp nicks that could damage or tear paper rolls. Grind edges smooth.
- Check the load-holding hydraulic system for proper functions. Cascade Clamp Force Indicators 830141 and 832442 are available for this test.
- Remove tape, glue and wrapper/paper fibers from contact pads.
- Check decals and nameplate for legibility.
- **Initial 500 Hours** – Check rotator drive gearcase lubricant level. Lubricant should be filled up to the level hole. If needed, add lubricant through the fill hole. Use Cascade Rotator Drive Lubricant, Part No. 656300 or SAE 90 wt. gear lube (AGMA 'mild' 6 EP Gear Oil). Replace the plug.

### 1000-Hour Maintenance

After each 1000 hours of truck operation, in addition to the daily inspection, perform the following procedures:

- Check the torque on the stop block capscrews and tighten to 110 Nm if necessary.
- Check a sample of baseplate rotation bearing capscrews for proper torque value. For inspection and replacement procedures, refer to one of the following publications:
  - Technical Bulletin TB183
  - 10H Service Manual, part no. 6862661
  - 13H Service Manual, part no. 6839447
  - 18H Service Manual, part no. 6805681
- Check a sample of faceplate rotation bearing capscrews for proper torque value. For inspection and replacement procedures, refer to one of the following publications:
  - Technical Bulletin TB183
  - 10H Service Manual, part no. 6862661
  - 13H Service Manual, part no. 6839447
  - 18H Service Manual, part no. 6805681



**WARNING:** After completing any service procedure, always test the attachment through five complete cycles. First test empty, then test with load to make sure attachment operates correctly before returning it to the job.

**WARNING:** Before starting any work on the unit, the operator must wear the appropriate personal protective equipment (PPE) such as gloves, eye protection and safety shoes. Refer to page 1 for more information.

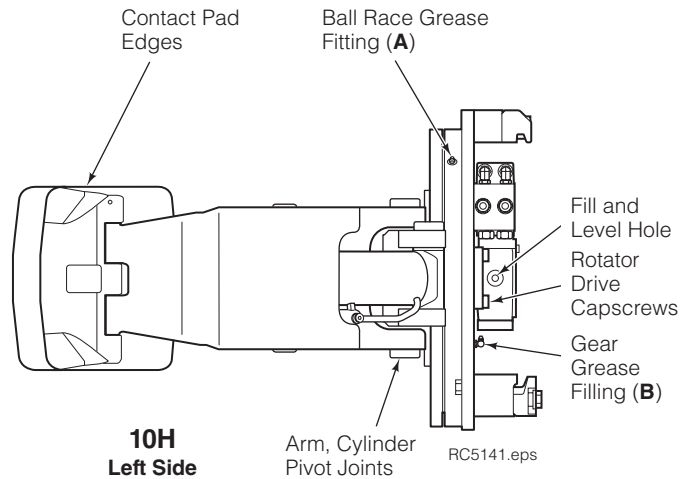

**WARNING:** A sampling of rotation capscrews must be checked for proper torque at 1000 hours (see TB183). A complete inspection is required every 2000 hours. Failure to keep the capscrews tightened can result in attachment damage and serious injury.

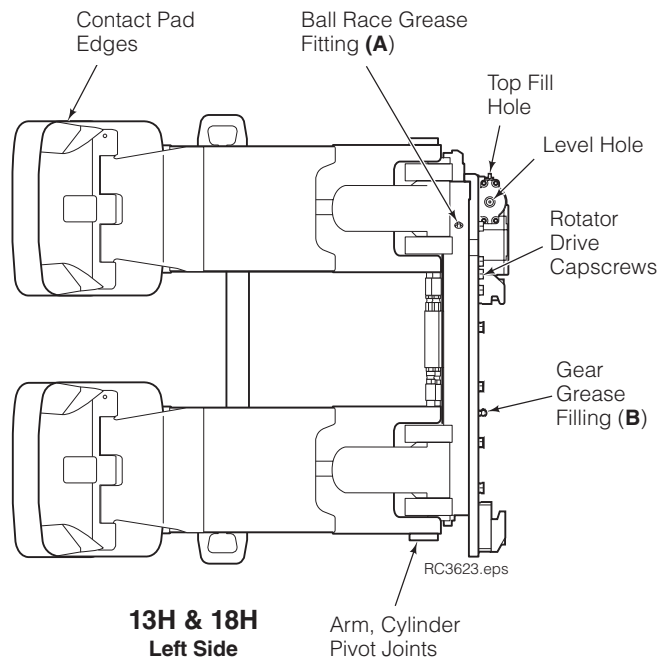

## 10H-18H (continued)

### 1000-Hour Maintenance (continued)

- Tighten lower mounting hook capscrews to 165 Nm.
- Tighten rotator drive capscrews to 32 Nm.
- Lubricate rotator bearing assembly ball race (**A**) and gear (**B**) with EP-2 grease. (Whitmore 'OmniTask' or equivalent). Rotate attachment in 90 degree increments and grease in each position.
- Inspect all arm, frame and cylinder pivot bushings for wear. Replace if necessary.
- Inspect all load-bearing structural welds on arms, arm pivots and cylinder pivot areas for visual cracks. Replace components as required.
- Inspect wear tile, arm tips and contact pads for wear and damage. Replace or repair, as needed.
- Change rotator drive gearcase lubricant. Drain oil out the case drain hole. Fill through the fill hole up to the level hole. Use Cascade Rotator Drive Lubricant, Part No. 656300, or SAE 90 wt. gear lube (AGMA 'mild' 6 EP Gear Oil). Replace plug.

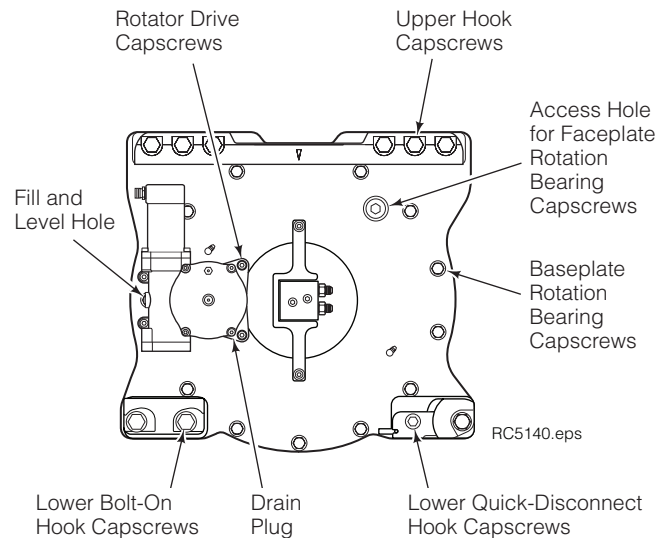

**10H**  
Back (Driver's) Side

### 2000-Hour Maintenance

After each 2000 hours of truck operation, in addition to the daily inspection and 1000-hour maintenance, perform the following procedures:

- Check **all** rotation bearing capscrews for proper torque value. For inspection and replacement procedures, refer to one of the following publications:
  - Technical Bulletin TB183
  - 10H Service Manual, part no. 6862661
  - 13H Service Manual, part no. 6839447
  - 18H Service Manual, part no. 6805681
- Inspect all arm and cylinder pivot pins for wear and replace if necessary.

### 4000-Hour Maintenance

After each 4000 hours of truck operation, in addition to the daily inspection, 1000-hour and 2000-hour maintenance, perform the following procedures:

- Due to normal mechanical wear and component service life, cylinder seals should be replaced to maintain performance and safe operation.

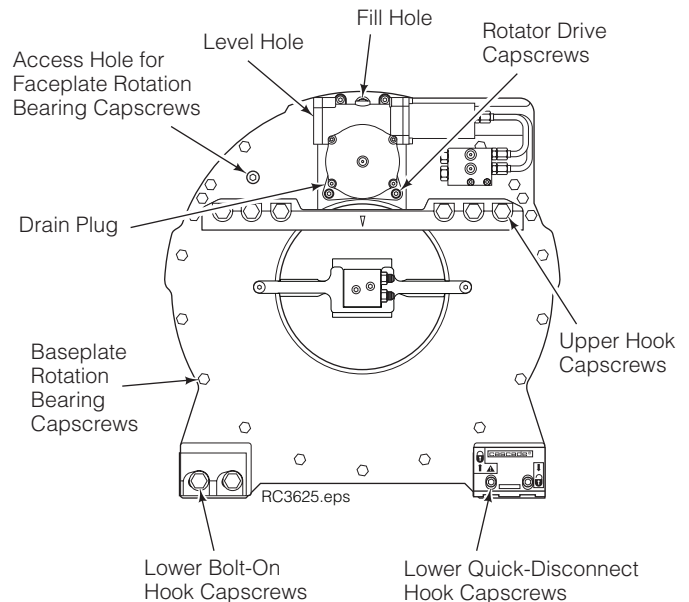

**13H & 18H**  
Back (Driver's) Side

## 20H–75H

### Prior to Maintenance

Before performing any maintenance procedure, verify the following:

- Relieve hydraulic system pressure,
- Make sure the oil is cool,
- If necessary, operate with the set truck/equipment in a stable position defined by the truck manufacturer.

### Daily Inspection

Check items shown each day. Report problems to a supervisor. Refer to service manual for troubleshooting, maintenance and repair procedures.

- Check for the following:
  - Loose or missing hardware,
  - Worn or damaged hoses,
  - Hydraulic leaks
- Check edges of contact pads for wear or sharp nicks that could damage or tear paper rolls. Grind edges smooth.
- Check the load-holding hydraulic system for proper functions. Cascade Clamp Force Indicators 830141 and 832442 are available for this test.
- Remove tape, glue and wrapper/paper fibers from contact pads.
- Check decals and nameplate for legibility.

### 1000-Hour Maintenance

After each 1000 hours of truck operation, in addition to the daily inspection, perform the following procedures:

- Check the torque on the stop block capscrews and tighten to 110 Nm if necessary.
- Check a sample of baseplate rotation bearing capscrews for proper torque value. See Technical Bulletin TB183 or Service Manual 6078255 for inspection and replacement procedures.
- Check a sample of faceplate rotation bearing capscrews for proper torque value. See Technical Bulletin TB183 or Service Manual 6078255 for inspection and replacement procedures.
- Tighten lower mounting hook capscrews to:
  - Class II/III** – 165 Nm
  - Class IV** – 320 Nm
- Tighten rotator drive capscrews to 88 Nm.
- Lubricate rotator bearing assembly ball race (A) and gear (B) with EP-2 grease. (Whitmore 'Omnitask' or equivalent). Rotate attachment in 90 degree increments and grease in each position.
- Check rotator drive gearcase lubricant level. Lubricant should be filled up to end cover level hole. Add lubricant through the end cover hole.

If necessary, fill with Cascade Rotator Drive Lubricant, Part No. 656300 or SAE 90 wt. gear lube (AGMA 'mild' 6 EP Gear Oil). Replace the plug.

**NOTE:** Use funnel or squeeze bottle to assist with adding lubricant. If access to the fill hole location is limited, fill using the vent hole. Prior to filling, remove fill hole fitting to watch lubricant level.



**WARNING:** After completing any service procedure, always test the attachment through five complete cycles. First test empty, then test with load to make sure attachment operates correctly before returning it to the job.

**WARNING:** Before starting any work on the unit, the operator must wear the appropriate personal protective equipment (PPE) such as gloves, eye protection and safety shoes. Refer to page 1 for more information.

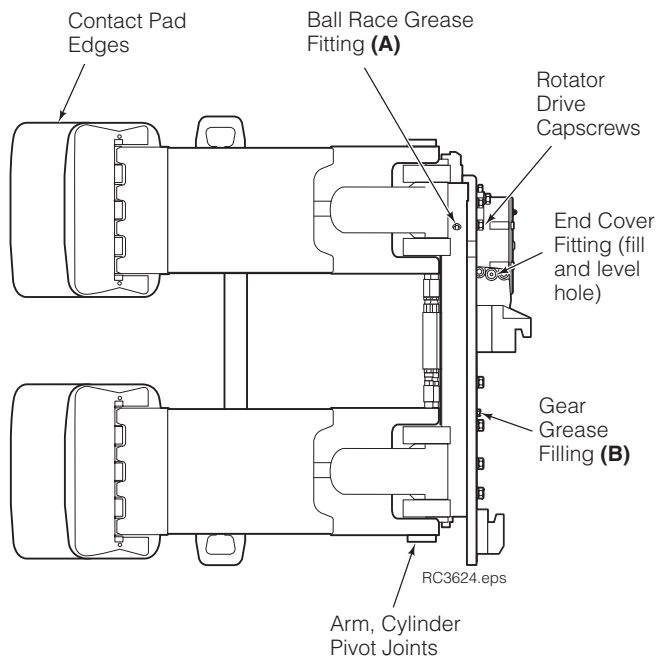

**WARNING:** A sampling of rotation capscrews must be checked for proper torque at 1000 hours (see TB183). A complete inspection is required every 2000 hours. Failure to keep the capscrews tightened can result in attachment damage and serious injury.

## 20H–75H (continued)

### 1000-Hour Maintenance (continued)

- Inspect all arm, frame and cylinder pivot bushings for wear. Replace if necessary.
- Inspect all load-bearing structural welds on arms, arm pivots and cylinder pivot areas for visual cracks. Replace components as required.
- Inspect wear tile, arm tips and contact pads for wear and damage. Replace or repair, as needed.

### 2000-Hour Maintenance

After each 2000 hours of truck operation, in addition to the daily inspection and 1000-hour maintenance, perform the following procedures:

- Check **all** rotation bearing capscrews for proper torque value. See Technical Bulletin TB183, Service Manual 6078255 for inspection and replacement procedures.
- Inspect all arm and cylinder pivot pins for wear and replace if necessary.

### 4000-Hour Maintenance

After each 4000 hours of truck operation, in addition to the daily inspection, 1000-hour and 2000-hour maintenance, perform the following procedures:

- Due to normal mechanical wear and component service life, cylinder seals should be replaced to maintain performance and safe operation.

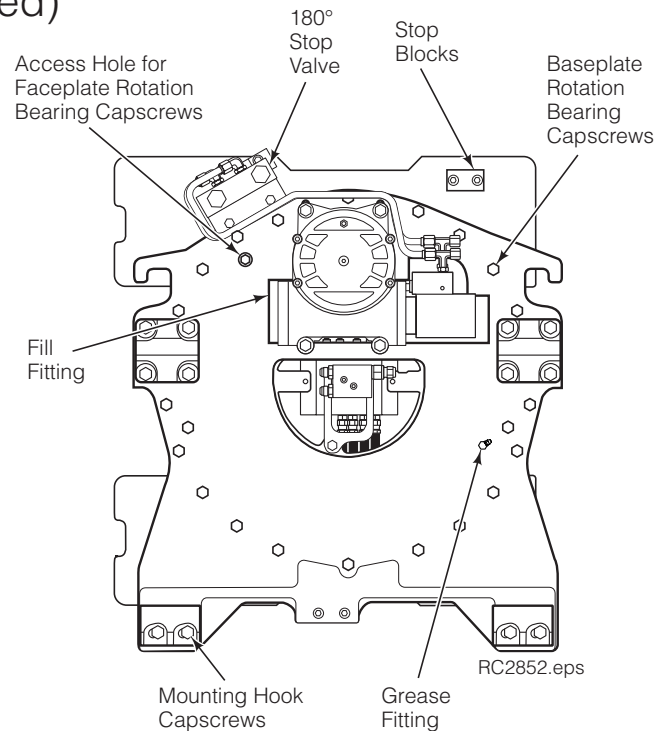

**20H-46H**  
**Back (Driver's Side)**

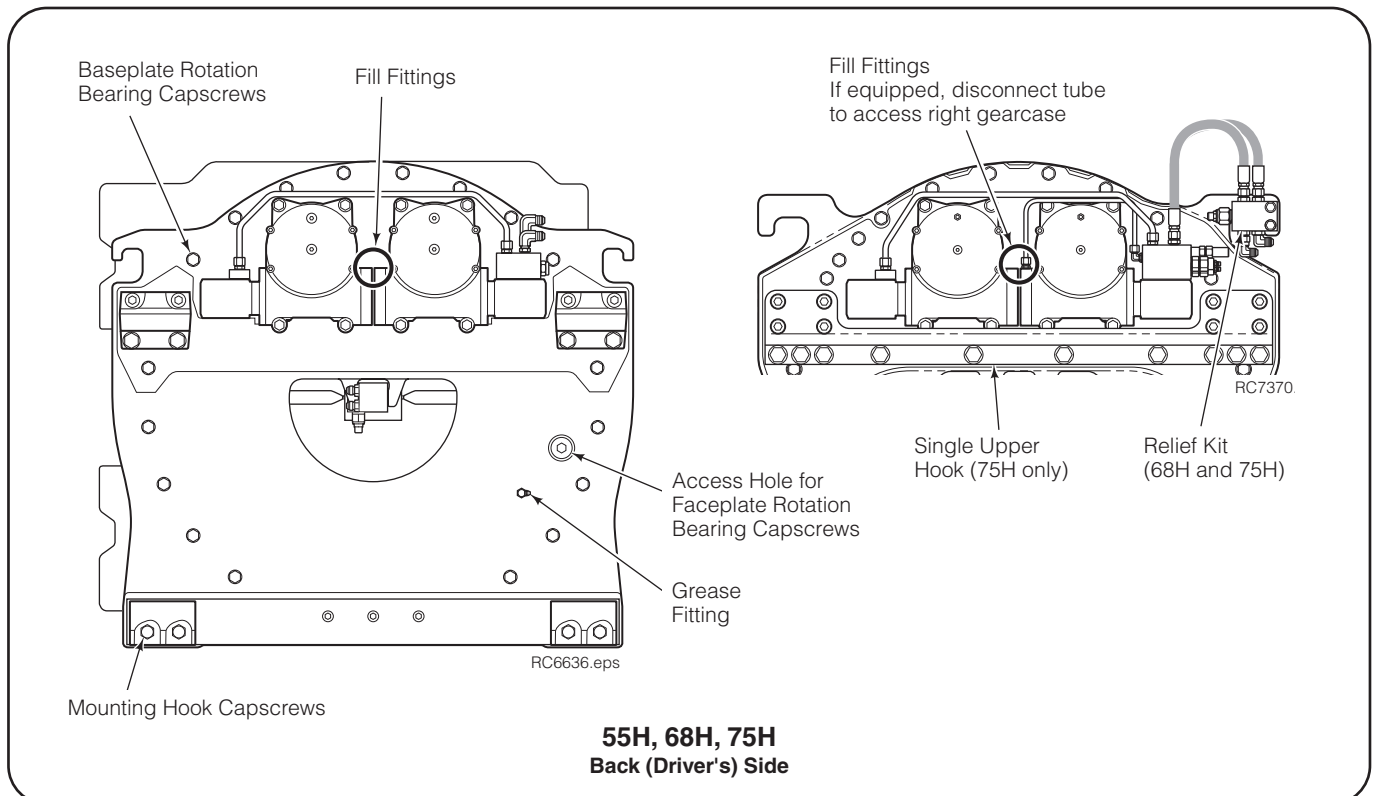

**55H, 68H, 75H**  
**Back (Driver's Side)**

## Rotate Function Evaluation

The following procedure should be performed every 1000 hours of truck/attachment operation:

- 1 Clamp a typical load that is within the capacity of the attachment/truck combination.
- 2 Raise the load the minimum amount to avoid hitting the floor during rotation.
- 3 Rotate the load Clockwise (CW) 120° and stop. No rotational drift should be observed within 30 seconds.
- 4 Rotate the load Counterclockwise (CCW) 30° to horizontal and stop. No rotational drift should be observed within 30 seconds.
- 5 Rotate the load Counterclockwise (CCW) 90° to return to the initial position.
- 6 Rotate the load Counterclockwise (CCW) 120° and stop. No rotational drift should be observed within 30 seconds.
- 7 Rotate the load Clockwise (CW) 30° to horizontal and stop. No rotational drift should be observed within 30 seconds.
- 8 Rotate the load Counterclockwise (CCW) 90° to return to the initial position.
- 9 Repeat Steps 3 – 8 two times to confirm observed conditions.
  - If no rotational drift is observed during the evaluation, no action is required.

**CAUTION:** If rotational drift is observed during the evaluation, contact the Cascade Service Department to assist with troubleshooting and symptom resolution.

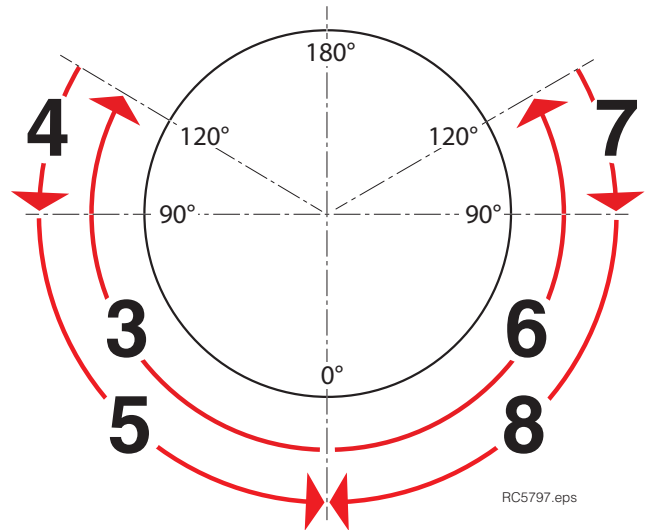
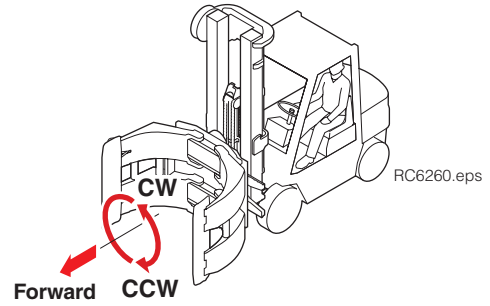

(EN) NAMEPLATE ICONS  
 (BG) ТАБЕЛКА С ИМЕ ИКОНИ  
 (CS) JMENOVKA IKONY  
 (DA) NAVNESKILT IKONER  
 (DE) TYPENSCHILD SYMBOLE  
 (EL) ΟΝΟΜΑΣΤΙΚΗΣ ΕΙΚΟΝΙΔΙΑ  
 (ES) PLACA DE ICONOS  
 (ET) NIMERPLAADI IKOONID  
 (FI) NIMIKYLTIT KUVAKKEET  
 (FR) PLAQUE ICÔNES  
 (GA) IDENTIFICACIÓN ICONAS  
 (HU) NÉVTÁBLÁN IKONOK  
 (IS) NAFNASKILTATÁKN  
 (IT) ICONE DELLA TARGA  
 (JA) 銘板アイコン  
 (KO) 명판 아이콘  
 (LT) NOMINALUS PIKTOGRAMOS  
 (LV) AR NOSAUKUMU, IKONAS  
 (MT) NAMEPLATE ICOANE  
 (NL) NAAMBORD ICONEN  
 (NO) NAVNEPLATE-IKONER  
 (PL) NAMEPLATE ICOANE  
 (PT) IDENTIFICAÇÃO ICONES  
 (RO) ICONOS DE PLACA  
 (RU) ТАБЛИЧКУ ЗНАЧКОВ  
 (SK) MENOVKA ICONS  
 (SL) TABLICA IKONE  
 (SV) NAMNSKYLTEN IKONER  
 (TR) BILGI ETIKETI SIMGELERI  
 (ZH) 铭牌图标

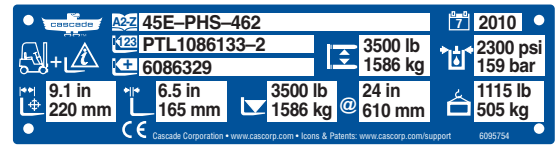

(EN) MODEL  
 (BG) МОДЕЛ  
 (CS) MODEL  
 (DA) MODEL  
 (DE) MODELL  
 (EL) ΜΟΝΤΕΛΟ  
 (ES) MODELO  
 (ET) MUDEL  
 (FI) MALLI  
 (FR) MODELE  
 (GA) DÉANAMH AGUS AINM  
 (HU) MODELL  
 (IS) MÓDEL  
 (IT) MODELLO  
 (JA) モデル  
 (KO) 모델  
 (LT) MODELIS  
 (LV) MODELIS  
 (MT) MUDELL  
 (NL) MODEL  
 (NO) MODELL  
 (PL) MODEL  
 (PT) MODELO  
 (RO) MODEL  
 (RU) МОДЕЛЬ  
 (SK) MODEL  
 (SL) MODEL  
 (SV) MODEL  
 (TR) MODEL  
 (ZH) 型号



(EN) SERIAL NUMBER  
 (BG) СЕРИЕН НОМЕР  
 (CS) SÉRIOVÉ ČÍSLO  
 (DA) SERIENUMMER  
 (DE) SERIENNUMMER  
 (EL) ΣΕΙΡΙΑΚΟΣ ΑΡΙΘΜΟΣ  
 (ES) NÚMERO DE SERIE  
 (ET) SEERIANUMBER  
 (FI) SARJANUMERO  
 (FR) NUMERO DE SERIE  
 (GA) SRAITHUIMHIR  
 (HU) GYÁRI SZÁM  
 (IS) RAÐNÚMÉR  
 (IT) NUMERO DI SERIE  
 (JA) シリアル番号  
 (KO) 일련 번호  
 (LT) SERIJINIS NUMERIS  
 (LV) SĒRIJAS NUMURS  
 (MT) NUMRU TAS-SERJE  
 (NL) SERIENUMMER  
 (NO) SERIENUMMER  
 (PL) NUMER SERYJNY  
 (PT) NÚMERO DE SÉRIE  
 (RO) NUMĂR DE SERIE  
 (RU) СЕРИЙНЫЙ НОМЕР  
 (SK) SÉRIOVÉ ČÍSLO  
 (SL) SERIJSKA ŠTEVILKA  
 (SV) SERIENUMMER  
 (TR) SERI NUMARASI  
 (ZH) 序列号



(EN) ADDITIONAL INFORMATION  
 (BG) ДОПЪЛНИТЕЛНА ИНФОРМАЦИЯ  
 (CS) DOPLŇKOVÉ INFORMACE  
 (DA) YDERLIGERE OPLYSNINGER  
 (DE) ZUSÄTZLICHE INFORMATIONEN  
 (EL) ΠΡΟΣΘΕΤΕΣ ΠΛΗΡΟΦΟΡΙΕΣ  
 (ES) INFORMACIÓN ADICIONAL  
 (ET) LISAINFO  
 (FI) LISÄTIETOJA  
 (FR) INFORMATIONS SUPPLÉMENTAIRES  
 (GA) TUILLÉADH FAISNÉISE  
 (HU) KIEGÉSZÍTŐ INFORMÁCIÓ  
 (IS) VIÐBÓTARTÆKI  
 (IT) INFORMAZIONI AGGIUNTIVE  
 (JA) 追加情報  
 (KO) 추가 정보  
 (LT) PAPILDOMA INFORMACIJA  
 (LV) PAPILDU INFORMĀCIJA  
 (MT) INFORMAZZJONI ADDIZZJONALI  
 (NL) AANVULLENDE INFORMATIE  
 (NO) TILLEGGSUTSTYR  
 (PL) INFORMACJE DODATKOWE  
 (PT) INFORMAÇÕES ADICIONAIS  
 (RO) INFORMAȚII SUPLEMENTARE  
 (RU) ДОПОЛНИТЕЛЬНАЯ ИНФОРМАЦИЯ  
 (SK) ĎALŠIE INFORMÁCIE  
 (SL) DODATNE INFORMACIJE  
 (SV) YTTERLIGARE INFORMATION  
 (TR) LAVVE EKIPMAN  
 (ZH) 其它信息



(EN) MAXIMUM CAPACITY  
 (BG) МАКСИМАЛЕН КАПАЦИТЕТ  
 (CS) MAXIMÁLNÍ NOSNOST  
 (DA) MAKS. KAPACITET  
 (DE) MAXIMALKAPAZITÄT  
 (EL) ΜΕΓΙΣΤΗ ΧΩΡΗΓΙΚΟΤΗΤΑ  
 (ES) CAPACIDAD MÁXIMA  
 (ET) MAKSIMAALNE JÕUDLUS  
 (FI) MAKSIMIKAPASITEETTI  
 (FR) CAPACITÉ MAXIMUM  
 (GA) UASCHUMAS  
 (HU) MAXIMÁLIS KAPACITÁS  
 (IS) HÁMARKS GETA  
 (IT) PORTATA MASSIMA  
 (JA) 最大容量  
 (KO) 최대 용량  
 (LT) MAKSIMALI GALIA  
 (LV) MAKSIMĀLA CELTSPĒJA  
 (MT) KAPACITÀ MASSIMA  
 (NL) MAXIMAAL LAADVERMOGEN  
 (NO) MAKSIMAL KAPASITET  
 (PL) UDŹWIG MAKSYMALNY  
 (PT) CAPACIDADE MÁXIMA  
 (RO) CAPACITATEA MAXIMĂ  
 (RU) МАКСИМАЛЬНАЯ ГРУЗОПОДЪЕМНОСТЬ  
 (SK) MAXIMÁLNA NOSNOSŤ  
 (SL) NAJVEČJA ZMOGLJIVOST  
 (SV) MAXIMAL KAPACITET  
 (TR) MAKSIMUM KAPASITE  
 (ZH) 最大承载能力



(EN) MAXIMUM CAPACITY BETWEEN FORKS  
 (BG) МАКСИМАЛНА ТОВАРОПОДЕМНОСТ МЕЖДУ ВИЛИЦИТЕ  
 (CS) MAXIMÁLNÍ NOSNOST MEZI VIDLICEMI  
 (DA) MAKSIMAL KAPASITET MELLEMLERNE  
 (DE) MAXIMALE TRAGFÄHIGKEIT ZWISCHEN DEN GABELN  
 (EL) ΜΕΓΙΣΤΗ ΙΚΑΝΟΤΗΤΑ ΑΝΑΜΕΣΑ ΣΤΙΣ ΠΕΡΟΝΕΣ  
 (ES) CAPACIDAD MÁXIMA ENTRE HORQUILLAS  
 (ET) KAHVILITE VAHELINE MAX. TÕSTEVÕIME  
 (FI) MAKSIMINOSTOKYKY HAARUKOIDEN VÄLISSÄ  
 (FR) CAPACITÉ MAXIMALE ENTRE LES FOURCHES  
 (GA) UASCHUMAS IDIR NA GABHAIL  
 (HU) MAXIMUM TEHERBÍRÁS VILLÁK KÖZÖTT  
 (IS) HÁMARKS GETA MILLI GAFLA  
 (IT) PORTATA MASSIMA TRA LE FORCHE  
 (JA) フォーク間の最大容量  
 (KO) 포크 간 최대 용량  
 (LT) MAKSIMALI GALIA TARP ŠAKIJ  
 (LV) MAKSIMĀLA CELTSPĒJA STARP DAKŠĀM  
 (MT) KAPACITÀ MASSIMA BEJN IL-FRIEKET  
 (NL) MAXIMUMCAPACITEIT TUSSEN VORKEN  
 (NO) MAKSIMAL KAPASITET MELLOM GAFLENE  
 (PL) MAKSYMALNY UDŹWIG POMIĘDZY WIDLAMI  
 (PT) CAPACIDADE MÁXIMA ENTRE GARFOS  
 (RO) CAPACITATEA MAXIMĂ ÎNTRE FURCI  
 (RU) МАКСИМАЛЬНАЯ ГРУЗОПОДЪЕМНОСТЬ МЕЖДУ ВИЛАМИ  
 (SK) MAXIMÁLNA NOSNOSŤ MEDZI VIDLICAMI  
 (SL) NAJVEČJA ZMOGLJIVOST MED VILICAMI  
 (SV) MAXIMAL KAPACITET MELLAN GAFFLAR  
 (TR) ÇATALLAR ARASI YÜK MERKEZİNDEKİ  
 (ZH) 最大承载能力



(EN) @ LOAD CENTER  
 (BG) В ЦЕНТЪРА НА НАТОВАРВАНЕ  
 (CS) @ STŘED NÁKLADU  
 (DA) VED LASTCENTRUM  
 (DE) @ LASTSCHWERPUNKT  
 (EL) ΣΤΟ ΚΕΝΤΡΟ ΒΑΡΟΥΣ  
 (ES) @ CENTRO DE CARGA  
 (ET) @ KOORMUSE RASKUSKESE  
 (FI) PAINOPISTEESSÄ  
 (FR) AU CENTRE DE CHARGE  
 (GA) @ LÓDPHOINTE  
 (HU) @ TEHER KÖZEPE  
 (IS) @ HLEDSLUMIÐJA  
 (IT) @ BARICENTRO DEL CARICO  
 (JA) @ 負荷の中心  
 (KO) @ 하중 중심  
 (LT) TIES KROVINIO CENTRU  
 (LV) KRĀVAS CENTRĀ  
 (MT) @ ĊENTRU TAT-TAGĦBIJA  
 (NL) BIJ LASTZWAARTEPUNT  
 (NO) VED LASTEPUNKT  
 (PL) @ ŚRODEK CIĘŻKOŚCI ŁADUNKU  
 (PT) @ CENTRO DE CARGA  
 (RO) LA CENTRUL DE GREUTATE  
 (RU) В ЦЕНТРЕ НАГРУЗКИ  
 (SK) V ŤAŽISKU NÁKLADU  
 (SL) @ SREDIŠČE OBREMNITVE  
 (SV) VID LASTENS MITTPUNKT  
 (TR) MAKSIMUM KAPASITE  
 (ZH) 载荷中心



(EN) MAXIMUM OPERATING PRESSURE  
 (BG) МАКСИМАЛНО РАБОТНО НАЛЯГАНЕ  
 (CS) MAXIMÁLNÍ PROVOZNÍ TLAK  
 (DA) MAKSIMALT DRIFTSTRYK  
 (DE) MAXIMALER BETRIEBSDRUCK  
 (EL) ΜΕΓΙΣΤΗ ΠΙΕΣΗ ΛΕΙΤΟΥΡΓΙΑΣ  
 (ES) PRESIÓN DE FUNCIONAMIENTO MÁXIMA  
 (ET) MAKSIMAALNE TÕÕRÕHK  
 (FI) MAKSIMITOIMINTAPAINE  
 (FR) PRESION DE SERVICE MAXIMALE  
 (GA) UASBHUR OIBRIUCHÁIN  
 (HU) MAXIMÁLIS ÜZEMI NYOMÁS  
 (IS) HÁMARKS VINNUPRÝSTINGUR  
 (IT) PRESSIONE MASSIMA DI ESERCIZIO  
 (JA) 最大運転圧力  
 (KO) 최대 작동 압력  
 (LT) MAKSIMALUS EKSPLOATACINIS SLĖGIS  
 (LV) MAKSIMĀLAIS DARBA SPĒDIENS  
 (MT) PRESSJONI MASSIMA TAL-OPERAT  
 (NL) MAXIMUM WERKDRUK  
 (NO) MAKSIMALT DRIFTSTRYKK  
 (PL) MAKSYMALNE CIŚNIENIE ROBOCZE  
 (PT) PRESSÃO MÁXIMA DE FUNCIONAMENTO  
 (RO) PRESIUNEA DE LUCRU MAXIMĂ  
 (RU) МАКСИМАЛЬНОЕ РАБОЧЕЕ ДАВЛЕНИЕ  
 (SK) MAXIMÁLNY PREVÁDZKOVÝ TLAK  
 (SL) NAJVEČJI DELOVNI TLAK  
 (SV) MAXIMALT ARBETSTRYCK  
 (TR) MAKSIMUM İŞLETME BASINCI  
 (ZH) 最大工作压力



(EN) MASS OF ATTACHMENT  
 (BG) МАСА НА ПРИСТАВКА  
 (CS) HMOTNOST PŘÍDAVNÉHO ZAŘÍZENÍ  
 (DA) UDSTYRS VÆGT  
 (DE) ANBAUGERÄTEGEWICHT  
 (EL) ΜΑΖΑ ΣΥΝΔΕΔΕΜΕΝΟΥ ΕΞΟΠΛΙΣΜΟΥ  
 (ES) PESO DEL ACCESORIO  
 (ET) TÕÕSEADM MASS  
 (FI) LISÄLAITTEEN PAINO  
 (FR) MASSE DE L'ACCESSOIRE  
 (GA) MAIS AN FHEISTIS  
 (HU) A SZERELÉK TÖMEGE  
 (IS) FJÖLDI TENGINGA  
 (IT) MASSA DELL'ATTREZZATURA  
 (JA) 装備総量  
 (KO) 부차 크기  
 (LT) PRIEDO MASĖ  
 (LV) UZKARES IEKĀRTAS MASA  
 (MT) PIŻ TAL-ATTACHMENT  
 (NL) MASSA VAN VOORZETAPPARAAT  
 (NO) MASSE FOR TILLEGGSUTSTYR  
 (PL) MASA OSPRZĘTU  
 (PT) PESO DO ACESSÓRIO  
 (RO) MASA ECHIPAMENTULUI ATAŞAT  
 (RU) МАССА НАВЕЩЕНОГО ОБОРУДОВАНИЯ  
 (SK) HMOTNOSŤ PRÍDAVNÉHO ZARIADENIA  
 (SL) MASA PRIKLJUČKA  
 (SV) AGGREGATETS VIKT  
 (TR) EK DONANIM AĞIRLIĞI  
 (ZH) 属具质量



(EN) LOST LOAD CENTER DISTANCE  
 (BG) РАЗСТОЯНИЕ ОТ ЦЕНТЪРА НА ЗАГУБА НА НАТОВАРВАНЕ  
 (CS) VZDALENOST POSUNUTÉHO STŘEDU NÁKLADU  
 (DA) REDUCERET LASTCENTERAFSTAND  
 (DE) VERLORENER ABSTAND ZUM LASTMITTELPUNKT  
 (EL) ΑΠΟΣΤΑΣΗ ΑΠΟΛΕΞΘΕΝΤΟΣ ΚΕΝΤΡΟΥ ΒΑΡΟΥΣ  
 (ES) DISTANCIA A CENTRO DE CARGA PERDIDA  
 (ET) KOORMUSE RASKUSKESKME MUUTUS  
 (FI) KAPASITEETIHUKAN KESKIPESTEEN ETÄISYYS  
 (FR) DISTANCE CENTRE DE CHARGE PERDUE  
 (GA) FAD LÓDPHOINTE CAILLTE  
 (HU) ELVESZETT TEHERKÖZEPONT-TÁVOLSÁG  
 (IS) FJARLÆGD GLATÁÐS HLEDSLUMIÐJU  
 (IT) SPESSORE EFFETTIVO  
 (JA) 荷重中心消失  
 (KO) 손실 하중 중심 거리  
 (LT) ATITOLUSIO APKROVOS CENTRO ATSTUMAS  
 (LV) ZAUDĒTIS ATTĀLUMS LĪDZ SLODZES CENTRAM  
 (MT) DISTANZA MIĊ-CENTRU TAT-TAGĦBIJA MITLUFA  
 (NL) VERLOREN AFSTAND TOT LASTZWAARTEPUNT  
 (NO) TAPT LASTEPUNKTAVSTAND  
 (PL) WIELKOŚĆ PRZESUNIĘCIA ŚRODKA CIĘŻKOŚCI ŁADUNKU  
 (PT) DISTANCIA DO CENTRO DE CARGA PERDIDA  
 (RO) DISTANTA LA CENTRUL DE GREUTATE AL SARCINII  
 (RU) ПОТЕРЯННОЕ РАСТОЯНИЕ ДО ЦЕНТРА НАГРУЗКИ  
 (SK) ÚBYTOK VYLOŽENIA ŤAŽISKA S PRÍDAVNÝM ZARIADENÍM  
 (SL) RAZDALJA DO PREKAMNENEGA SREDIŠČA OBREMNITVE  
 (SV) FÖRLORAT LASTMITTPUNKTSAVSTÅND  
 (TR) KAYIP YÜK MERKEZ MESAFESİ  
 (ZH) 荷載損耗中心距離



(EN) CENTER OF GRAVITY TO MOUNT FACE DISTANCE  
 (BG) ЦЕНТЪР НА ТЕЖЕСТТА СЪРЯМО ПАСТОЖИЕТО ОТ МОНТАЖНАТА ЧЕЛНА ПОВЪРХИНА  
 (CS) VZDÁLENOST STŘEDU NÁKLADU K ČELU RÁMU  
 (DA) AFSTANDEN MELLEM TYNGDEPUNKT OG MONTERINGSFLADEN  
 (DE) ABSTAND ZWISCHEN SCHWERPUNKT UND MONTAGEFLÄCHE  
 (EL) ΑΠΟΣΤΑΣΗ ΚΕΝΤΡΟΥ ΒΑΡΟΥΣ ΑΠΟ ΤΗΝ ΠΡΟΣΩΧΗ ΒΑΣΗ  
 (ES) DISTANCIA DE CENTRO DE GRAVEDAD A CARA DE MONTAJE  
 (ET) RASKUSKESKME KAUGUS EESMISEST KINNITUSPINNAST  
 (FI) PAINOPISTEEN ETÄISYYS KINNITYSPINNASTA  
 (FR) DISTANCE CENTRE DE GRAVITÉ-FACE DE MONTAGE

(GA) FAD IDIR AN MEÁCHANLÁR AGUS AN ÉADAN FEISTE  
 (HU) SÚLYPONT - SZERELŐFELÜLET TÁVOLSÁG  
 (IS) MIÐJA ÞYNGDARAFLS TIL AÐ HLADA ÚR LÍKAMSFJARLÆGÐ  
 (IT) CENTRO DI GRAVITA' DAL PIANO DI AGGANCIO  
 (JA) マウント面への重心  
 (KO) 장착 면 거리에 대한 중력 중심  
 (LT) ATSTUMAS NUO SJUNIO JĖGOS CENTRO KŪI PAGRINDO PRIEKINĖS PUSĖS  
 (LV) ATTĀLUMS NO SMAGUMA CENTRA LĪDZ UZSTĀDĪŠANAS VIRSMAI  
 (MT) ĊENTRU TA' GRAVITÀ SAD-DISTANZA MOUNT FACE  
 (NL) AFSTAND TUSSEN ZWAARTEPUNT EN MONTAGEVLAK

(NO) AVSTAND TYNGDEPUNKT TIL MONTERINGSFLATE  
 (PL) ODLEGŁOŚĆ OD ŚRODKA CIĘŻKOŚCI DO CZOŁA ZAWIESZENIA  
 (PT) DISTÂNCIA DO CENTRO DE GRAVIDADE À SUPERFÍCIE DE MONTAGEM  
 (RO) DISTANȚA DE LA CENTRUL DE GREUTATE LA SUPRAFAȚA DE MONTARE  
 (RU) РАСТОЯНИЕ ОТ ЦЕНТРА ТЯЖЕСТИ ДО УСТАНОВОЧНОЙ ПОВЕРХНОСТИ  
 (SK) VZDIALENOSŤ ŤAŽISKA OD ČELNEJ STRANY UCHYTENIA  
 (SL) RAZDALJA TEŽIŠČA OD SPREDNJE MONTAŽNE STRANI  
 (SV) AVSTÅND TYNGDPUNKT TILL MONTERINGSYTA  
 (TR) AĞIRLIK MERKEZİ İLE FORK YÜZÜ ARASI MESAFE  
 (ZH) 重心到安装面的距离



(EN) YEAR OF MANUFACTURE  
 (BG) ГОДИНА НА ПРОИЗВОДСТВО  
 (CS) ROK VÝROBY  
 (DA) PRODUKTIONSÅR  
 (DE) JAHR DER HERSTELLUNG  
 (EL) ΕΤΟΣ ΚΑΤΑΣΚΕΥΗΣ

(ES) AÑO DE FABRICACIÓN  
 (ET) VALMISTAMISAASTA  
 (FI) VALMISTUSVUOSI  
 (FR) ANNÉE DE FABRICATION  
 (GA) BLIAIN DÉANTÚSAÍOCHTA  
 (HU) A GYÁRTÁS ÉVE

(IS) FRAMLIDSÁR  
 (IT) ANNO DI FABBRICAZIONE  
 (JA) 製造年度  
 (KO) 제조년  
 (LT) PAGAMINIMO METAI  
 (LV) RAŽOŠANAS GADS

(MT) SENNA TA' MANIFATTURA  
 (NL) BOUWJAAR  
 (NO) PRODUKSJONSÅR  
 (PL) ROK PRODUKCJI  
 (PT) ANO DE FABRICO  
 (RO) ANUL DE FABRICAȚIE

(RU) ГОД ИЗГОТОВЛЕНИЯ  
 (SK) ROK VÝROBY  
 (SL) LETO IZDELAVE  
 (SV) TILLVERKNINGSÅR  
 (TR) ÜRETİM YILI  
 (ZH) 制造年份



(EN) CAPACITY OF TRUCK AND ATTACHMENT COMBINATION MAY BE LESS THAN ATTACHMENT CAPACITY SHOWN. CONSULT TRUCK NAMEPLATE. THE CAPACITY OF THE TRUCK AND ATTACHMENT COMBINATION SHALL BE COMPLIED WITH.  
 (BG) КАПАЦИТЕТЪТ НА СЪЕДИНЕНИТЕ ПОВДИГАЧ И ПРИСТАВКА МОЖЕ ДА БЪДЕ ПО-МАЛЪК ОТ ДАДЕНИЯ КАПАЦИТЕТ НА ПРИСТАВКАТА. ВИЖТЕ ТАБЕЛКАТА НА ПОВДИГАЧА. ТОВАРОПОДЕМНОСТТА НА КАРА И КОМБИНАЦИЯТА ОТ ПРИСТАВКИ ТРЯБВА ДА СЪОТВЕТСТВАТ.  
 (CS) NOSNOST KOMBINACE VOZÍKU Š PŘÍDAVNÝM ZAŘIZENÍM MUŽE BÝT MENŠÍ NEŽ UVEDENÁ NOSNOST PŘÍDAVNÉHO ZAŘIZENÍ. PROHLÉDNĚTE SI ŠTÍTEK VOZÍKU. NOSNOST KOMBINACE VOZÍKU A PŘÍDAVNÉHO ZAŘIZENÍ NESMÍ BÝT PŘEKROČENA.  
 (DA) DEN SAMLEDE KAPACITET FOR TRUCKEN OG DET PÅMONTEREDE TILBEHØR KAN VÆRE MINDRE END DEN VISTE KAPACITET FOR TILBEHØRET. SE TRUCKENS NAVNEPLADE. KOMBINATIONEN AF TRUCKENS KAPACITET OG TILBEHØRET SKAL OVERHOLDES.  
 (DE) DIE TRAGKRAFT DER KOMBINATION AUS STAPLER UND ANBAUGERÄT KANN GERINGER SEIN ALS DIE ANGEGEBENE NENNTRAGFÄHIGKEIT. SIEHE TYPENSCHILD. DIE TRAGFÄHIGKEIT DER STAPLER-ANBAUGERÄT-KOMBINATION MUSS DAMIT ÜBEREINSTIMMEN.  
 (EL) Η ΧΩΡΗΤΙΚΟΤΗΤΑ ΤΟΥ ΟΧΗΜΑΤΟΣ ΚΑΙ ΣΥΝΔΥΑΣΜΟΥ ΕΞΑΡΤΗΜΑΤΩΝ ΕΝΔΕΧΕΤΑΙ ΝΑ ΕΙΝΑΙ ΧΑΜΗΛΟΤΕΡΗ ΑΠΟ ΤΗ ΧΩΡΗΤΙΚΟΤΗΤΑ ΤΟΥ ΕΞΑΡΤΗΜΑΤΟΣ ΣΤΟ ΠΑΡΑΔΕΙΓΜΑ. ΣΥΜΒΟΥΛΕΥΤΕΙΤΕ ΤΗΝ ΕΤΙΚΕΤΑ ΟΧΗΜΑΤΟΣ. Η ΙΚΑΝΟΤΗΤΑ ΤΟΥ ΟΧΗΜΑΤΟΣ ΚΑΙ ΤΟΥ ΣΥΝΔΕΔΕΜΕΝΟΥ ΕΞΟΠΛΙΣΜΟΥ ΠΡΕΠΕΙ ΝΑ ΕΙΝΑΙ ΣΥΜΒΑΤΕΣ.  
 (ES) LA CAPACIDAD COMBINADA DE CARRETILLA Y ACCESORIO PUEDE SER MENOR QUE LA CAPACIDAD DEL ACCESORIO INDICADA. CONSULTE LA PLACA DE CARACTERÍSTICAS DE LA CARRETILLA. DEBE CUMPLIRSE LA CAPACIDAD COMBINADA DE CARRETILLA Y ACCESORIO.  
 (ET) LAADURI JA TÕÕSEADME KOMBINATSIOONI JÕUDLUS VÕIB OLLA VÄIKSEM KUI TÕÕSEADME NÄIDATUD JÕUDLUS. VAADAKE LAADURI ANDMEPLAATI. LAADUR JA TÕÕSEADE PEAVAD OLEMA ÜKSTEISEGA VASTAVUSES.  
 (FI) TRUKKI- JA LISÄLAITEYHDISTELMÄN KAPASITEETTI VOI OLLA PIENEMPI KUIN LISÄLAITTEEN ILMOITETTU KAPASITEETTI. KS. TRUKIN ARVOKILPI. TRUKIN JA LISÄLAITTEEN YHDISTELMÄN NOSTOKYKYÄ ON NOUDATETTAVA.  
 (FR) LA CAPACITE DE LA COMBINAISON CHARIOT/ACCESSOIRE PEUT S'AVERER INFÉRIEURE À CELLE INDICÉE POUR L'ACCESSOIRE. SE REPORTER À LA PLAQUE SIGNALÉTIQUE DU CHARIOT. RESPECTER LA CAPACITÉ DU CHARIOT ET DE L'ACCESSOIRE COMBINÉS.  
 (GA) D'FHÉADFADH NÍOS LÚ CUMAIS A BHEITH AG AN TRUCAIL AGUS FEISTEAS NÁ AN CUMAS FEISTIS A THAISPEÁNTAR. Féach ar ainmchlár na trucaile. Cloífeáir le cumas na trucaile agus an chomhcheangal feistis.  
 (HU) A TARGONCA ÉS A TARTOZÉK KOMBINÁCIÓ KAPACITÁSA LEHET, HOGY KEVESEBB, MINT AZ ÁBRÁZOLT TARTOZÉK KAPACITÁSA. LÁSD A TARGONCA ADATTÁBLÁN. A TARGONCA ÉS SZERELÉK KOMBINÁCIÓ TEHERBÍRÁSÁNAK ELEGET KELL TENNIE ENNEK.  
 (IS) GETA VÖRUBÍLS OG VIÐHENGISVIÐBÓTAR GETUR VERIÐ MINNI EN GETA VIÐHENGIS ER SÝND. RÁÐFÆRIÐ YKKUR VIÐ NAFNASKILTI VÖRUBÍLSINS. ÞAÐ Á AÐ FYLGJA GETU VÖRUBÍLSINS OG VIÐHENGISVIÐBÓTINI.  
 (IT) LA PORTATA DELLA COMBINAZIONE CARRELLO/ATTREZZATURA PUÒ ESSERE INFERIORE RISPETTO ALLA PORTATA DELLE ATTREZZATURE DICHIARATE. CONSULTARE LA TARGHETTA DEL CARRELLO. DEVE ESSERE RISPETTATA LA PORTATA DELLA COMBINAZIONE CARRELLO ELEVATORE/ATTREZZATURA.  
 (JA) フォークリフトの能力と装備の組み合わせは示されている装備の能力より低い場合があります。フォークリフトのネームプレートを相談。トラックの容量と装備の組み合わせとは実施済み。  
 (KO) 트럭 및 부속 결합물의 용량은 표시된 부속을 용량보다 적을 수 있습니다. 트럭 명판을 참조하십시오. 트럭 및 부속을 결합의 용량을 준수해야 합니다.  
 (LT) KRAUTUVO IR PRIEDO DERINIO GALINGUMAS GALI BŪTI MAŽESNIS NEGU NURODYTAS PRIEDO GALINGUMAS. SKAITYKITE INFORMACIJĄ KRAUTUVO INFORMACINĖJE PLOKŠTELĖJE. BŪTINA NEVIRŠYTI KRAUTUVO IR PRIEDO DERINIO GALIOS.  
 (LV) AUTOIEKRĀVĒJA UN PIEDERUMA KOPĒJĀ CELTSPĒJA VAR BŪT MAŽĀKA PAR NORĀDĪTO PIEDERUMA CELTSPĒJU. SKATĪT AUTOIEKRĀVĒJA TEHNISKO DATU PLĀKSNĪTI. IR JĀIEVĒRO AUTOIEKRĀVĒJA UN UZKARES IEKĀRTAS KOPĒJĀ CELTSPĒJA.  
 (MT) IL-KAPACITÀ TAT-TRAKK U TAT-TAGHMIR IMQABBAD MIEGHU TISTA' TKUN INQAS MILL-KAPACITÀ MURĪJA TAT-TAGHMIR IMQABBAD MIEGHU. IĊĊEKKJA L-PANĊA TAL-ISEM TAT-TRAKK. IL-KAPACITÀ TAT-TRAKK FLIMKIEN MA' DIK TAT-TAGHMIR IMQABBAD MIEGHU TRID TIĠI SSODISFATA.  
 (NL) HET DRAAGVERMOGEN VAN DE COMINATIE VAN HEFTRUCK EN VOORZETAPPARAAT KAN LAGER ZIJN DAN HET VERMELDE DRAAGVERMOGEN VAN HET VOORZETAPPARAAT. KIJK OP HET TYPEP LAATJE VAN DE HEFTRUCK. MET DE CAPACITEIT VAN DE COMBINATIE VAN TRUCK EN VOORZETAPPARAAT WORDT REKENING GEHOUDEN.  
 (NO) TOTAL KOMBINERT KAPASITET FOR GAFFELTRUCK OG TILBEHØR KAN VÆRE MINDRE ENN ANGIT KAPASITET FOR TILBEHØRET. SE GAFFELTRUCKENS NAVNEPLATE. DEN TOTALE KAPASITETEN FOR GAFFELTRUCK OG TILLEGGSUTSTYR KOMBINERT MÅ OVERHOLDES.  
 (PL) UDŹWIG ZESPOŁU WÓZKA I OSPRZĘTU MOŻE BYĆ MNIEJSZY NIŻ POKAZANY UDŹWIG OSPRZĘTU. PATRZ TABLICZKA ZNAMIONOWA WÓZKA. NALEŻY PRZESTRZEGAĆ DOPUSZCZALNEGO UDŹWIGU ZESPOŁU WÓZKA I OSPRZĘTU.  
 (PT) A CAPACIDADE DA COMBINAÇÃO DO EMPILHADOR E DO ACESSÓRIO PODE SER INFERIOR À CAPACIDADE DO ACESSÓRIO APRESENTADA. CONSULTE A CHAPA DE ESPECIFICAÇÕES DO EMPILHADOR. CAPACIDADE DO CAMINHÃO E COMBINAÇÃO DE PENHORA DEVE SER RESPEITADO.  
 (RO) CAPACITATEA VEHICULULUI ȘI A COMBINATIEI DISPOZITIVELOR DE PRINDERE POATE FI MAI MICĂ DECĂT CAPACITATEA DISPOZITIVELOR DE PRINDERE INDICATĂ. CONSULTAȚI PLĂCUȚA CU CARACTERISTICILE TEHNICE ALE STIVITORULUI. CAPACITATEA COMBINATIEI STIVITOR - ECHIPAMENTE ATAȘATE TREBUIE RESPECTATĂ.  
 (RU) СОВМЕСТНАЯ ГРУЗОПОДЪЕМНОСТЬ АВТОПОГРУЗЧИКА И НАВЕСНОГО УСТРОЙСТВА МОЖЕТ БЫТЬ НИЖЕ УКАЗАННОЙ ГРУЗОПОДЪЕМНОСТИ НАВЕСНОГО УСТРОЙСТВА. СМ. ТАБЛИЧКУ ТЕХНИЧЕСКИХ ДАННЫХ. НЕОБХОДИМО СОБЛЮДАТЬ КОМБИНИРОВАННУЮ ГРУЗОПОДЪЕМНОСТЬ АВТОПОГРУЗЧИКА И НАВЕСНОГО ОБОРУДОВАНИЯ.  
 (SK) NOSNOSŤ VOZÍKA A PŘÍDAVNÉHO ZARIADENIA MÔŽE BÝT MENŠIA AKO UVEDENÁ NOSNOSŤ PŘÍDAVNÉHO ZARIADENIA. BLIŽŠIE INFORMÁCIE UVEDENÉ NA TYPOVOM ŠTÍTKU VOZÍKA. NOSNOSŤ VOZÍKA S PŘÍDAVNÝM ZARIADENÍM BUDE DODRŽANÁ.  
 (SL) ZMOGLJIVOST KOMBINACIJE VILICARJA IN OPREME JE LAHKO MANJŠA OD PRIKAZANE ZMOGLJIVOSTI OPREME. UPOŠTEVAJTE NAPISNO PLOŠČICO VILICARJA. UPOŠTEVATI JE POTREBNO ZMOGLJIVOST KOMBINACIJE VILICARJA IN OPREME.  
 (SV) KAPACITETEN FÖR KOMBINATIONEN GAFFELTRUCK OCH AGGREGAT KAN VARA MINDRE ÄN ANGIVEN KAPACITET. LÄS GAFFELTRUCKENS TYP SKYL. KAPACITETEN FÖR KOMBINATIONEN GAFFELTRUCK OCH AGGREGAT SKA FÖLJAS.  
 (TR) ARAÇ KAPASİTESİ VE DONANIM KOMBİNASYONU, GÖSTERİLEN DONANIM KAPASİTESİNDEN DÜŞÜK OLABİLİR. ARAÇ BİLGİ ETİKETİNE BAŞVURUN. ARAÇ KAPASİTESİ VE DONANIM KOMBİNASYONU UYUMLU OLMALIDIR.  
 (ZH) 叉车与叉车属具的综合承载能力可能小于显示的叉车属具承载能力。请参考叉车铭牌。应符合叉车与叉车属具的综合承载能力。

BLANK

- (EN)** **Do you have questions you need answered right now?**  
Call your nearest Cascade Service Department.  
Visit us online at [www.cascorp.com](http://www.cascorp.com)
- (NL)** **Zijn er vragen waarop u direct een antwoord nodig hebt?**  
Neem dan contact op met uw dichtstbijzijnde serviceafdeling van Cascade. Of ga naar [www.cascorp.com](http://www.cascorp.com)
- (DE)** **Haben Sie Fragen, für die Sie sofort eine Antwort benötigen?**  
Wenden Sie sich an Ihren nächsten Cascade-Kundendienst. Besuchen Sie uns online: [www.cascorp.com](http://www.cascorp.com)
- (FR)** **En cas de questions urgentes,**  
contacter le service d'entretien Cascade le plus proche. Visiter le site Web [www.cascorp.com](http://www.cascorp.com).
- (IT)** **Per domande urgenti contattare**  
l'Ufficio Assistenza Cascade più vicino. Visitate il nostro sito all'indirizzo [www.cascorp.com](http://www.cascorp.com)
- (ES)** **¿Tiene alguna consulta que deba ser respondida de inmediato?** Llame por teléfono al servicio técnico de Cascade más cercano. Visítenos en [www.cascorp.com](http://www.cascorp.com)
- (CS)** **Máte nějaké dotazy, na které nyní potřebujete odpověď?**  
Zavolejte na nejbližší servisní oddělení Cascade. Navštivte naši webovou stránku [www.cascorp.com](http://www.cascorp.com)
- (FI)** **Tarvitsetko heti vastauksen kysymykseesi?**  
Ota yhteys lähimpään Cascade-huoltoon. Käy Internet-sivustollamme [www.cascorp.com](http://www.cascorp.com)
- (HU)** **Van olyan kérdése, amelyre most azonnal választ vár?**  
Hívja fel a legközelebbi Cascade Szervizszéleget. Keresse fel honlapunkat a [www.cascorp.com](http://www.cascorp.com) címen
- (NO)** **Har du spørsmål du trenger svar på akkurat nå?** Kontakt den nærmeste Cascade-serviceavdelingen. Besøk oss på Internett under [www.cascorp.com](http://www.cascorp.com)
- (PL)** **Czy potrzebne są teraz odpowiedzi na jakieś pytania?**  
Prosimy skontaktować się telefonicznie z najbliższym Działem Serwisowym Cascade. Zapraszamy do naszej witryny internetowej pod adresem [www.cascorp.com](http://www.cascorp.com)
- (SK)** **Máte nejaké otázky a potrebujete odpoveď ihneď?**  
Zavolajte najbližšie servisné stredisko spoločnosti Cascade. Pozrite si naše internetové stránky [www.cascorp.com](http://www.cascorp.com)

## AMERICAS

### Cascade Corporation U.S. Headquarters

2201 NE 201st  
Fairview, OR 97024-9718  
Tel: 800-CASCADE (227-2233)  
Fax: 800-693-3768

### Cascade Canada Inc.

5570 Timberlea Blvd.  
Mississauga, Ontario  
Canada L4W-4M6  
Tel: 905-629-7777  
Fax: 905-629-7785

### Cascade México

Almacén Dicex PDN  
Libramiento Noroeste  
4001 Km 27.5  
Parque Industrial Puerta del Norte  
Escobedo N.L 66050  
México  
Tel: 800-CASCADE (227-2233)

### Cascade Brasil

Av. Casa Grande, 850  
Casa Grande, Diadema SP,  
09961-350  
Tel: +55 11 4930-9800

### Anval – Cascade Distributor

Av. El Ventisquero 1225,  
Bodega 99,  
Renca – Santiago, Chile  
8661516  
Tel: +56 2 29516907

## EUROPE-AFRICA

### Cascade Italia S.R.L. European Headquarters

Via Dell'Artigianato 1  
37030 Vago di Lavagno (VR)  
Italy  
Tel: 39-045-8989111  
Fax: 39-045-8989160

### Cascade (Africa) Pty. Ltd.

PO Box 625, Isando 1600  
60A Steel Road  
Sparton, Kempton Park  
South Africa  
Tel: 27-11-975-9240  
Fax: 27-11-394-1147

## ASIA-PACIFIC

### Cascade Japan Ltd.

2-23, 2-Chome,  
Kukuchi Nishimachi  
Amagasaki, Hyogo  
Japan, 661-0978  
Tel: 81-6-6420-9771  
Fax: 81-6-6420-9777

### Cascade Korea

121B 9L Namdong Ind.  
Complex, 691-8 Gojan-Dong  
Namdong-Ku  
Inchon, Korea  
Tel: +82-32-821-2051  
Fax: +82-32-821-2055

### Cascade-Xiamen

No. 668 Yangguang Rd.  
Xinyang Industrial Zone  
Haicang, Xiamen City  
Fujian Province  
P.R. China 361026  
Tel: 86-592-651-2500  
Fax: 86-592-651-2571

### Cascade India Material Handling Pvt Ltd

Gat. No. 319/1 & 319/2, Village Kuruli,  
Taluka Khed, Pune 410 501  
Maharashtra, India  
Tel: +91 77200 25749 / 48

### Cascade Australia Pty. Ltd.

36 Kiln Street  
Darra QLD 4076  
Australia  
Tel: 1-800-227-223  
Fax: +61 7 3373-7333

### Cascade New Zealand

9 Blackburn Rd  
East Tamaki, Auckland  
New Zealand  
Tel: +64-9-273-9136

### Sunstream Industries Pte. Ltd. – Cascade Distributor

18 Tuas South Street 5  
Singapore 637796  
Tel: +65-6795-7555  
Fax: +65-6863-1368

